

Tap Changer Type KH F II

Specification, Assembly and Materials



Descriptions	Remarks
General Specifications	<ul style="list-style-type: none"> • available in one, two or three phase applications • multi layer types upon request • shaft length available in variable sizes • connection diagrams (page KHFI 7) can be applied in any variation to all types • bolted onto the supports • welded under transformer cover and allow strong construction

Materials

Steel Parts	<ul style="list-style-type: none"> • available in stainless or mild steel • mild steel parts are cadmium or zinc plated 	galvanizing upon request
Aluminium Parts	GAlSi12(Cu)	
Brass Parts	CuZn40Pb2 (CW617N) / F34 DIN 17 673	
Copper Parts	E - Cu F25 DIN 40 500	
Insulator Parts	Paper phenol - plastic resin based laminates, HP 2061.5 class of DIN 7735	
Upon Request	<ul style="list-style-type: none"> • the aluminum parts can be protected by anodic oxidation • the mild steel parts can be supplied in stainless steel • the brass and copper parts can be tin, silver or cadmium plated 	
Current	up to 400 A	
Voltage Class	B.I.L (other B. I. L. values are available upon customer request)	
20 kV / 30 kV / 60 kV	125 kV / 170 kV / 325 kV	

Operating Instructions

For each operation, the handle must first be pulled axially in the direction of the user in order to be subsequently rotated to the desired position. After being turned, the handle drops into the intended position by means of a high tension spring. Each position is precisely marked by a notch. This process is clearly marked on control knob as; „ **LIFT - TURN - SWITCH ON** „ (can be engraved in any language)

Type KHF II Threephase Tap Changer

Control Devices Incorporating a Handle / Unlocking by Axial Displacement of the Control Shaft

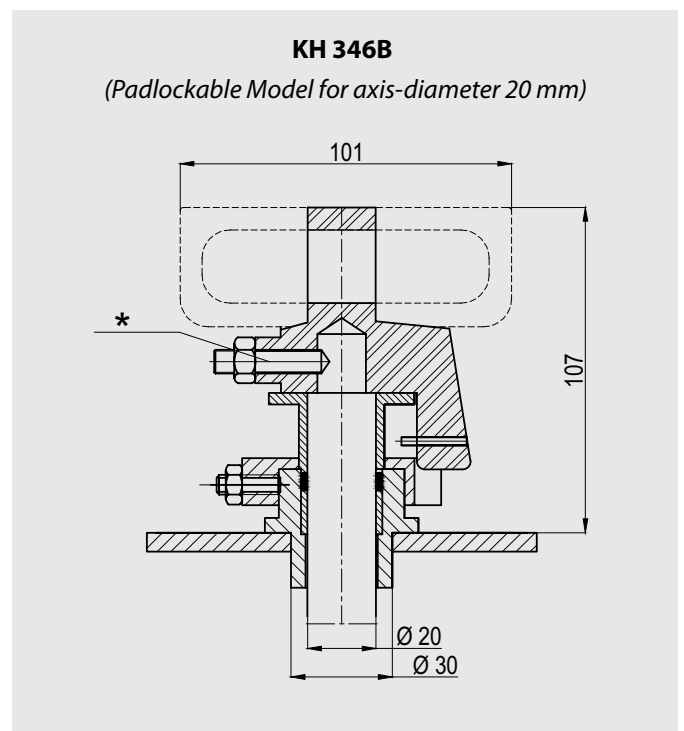
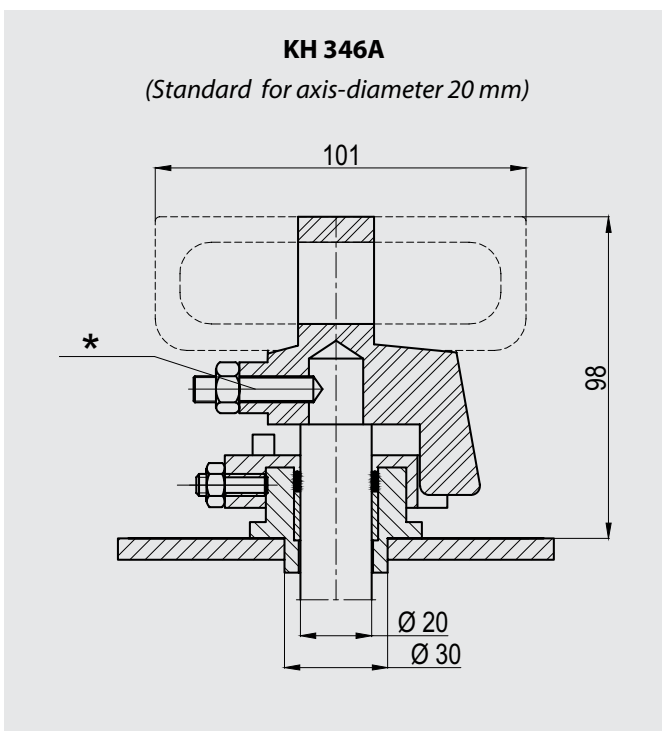
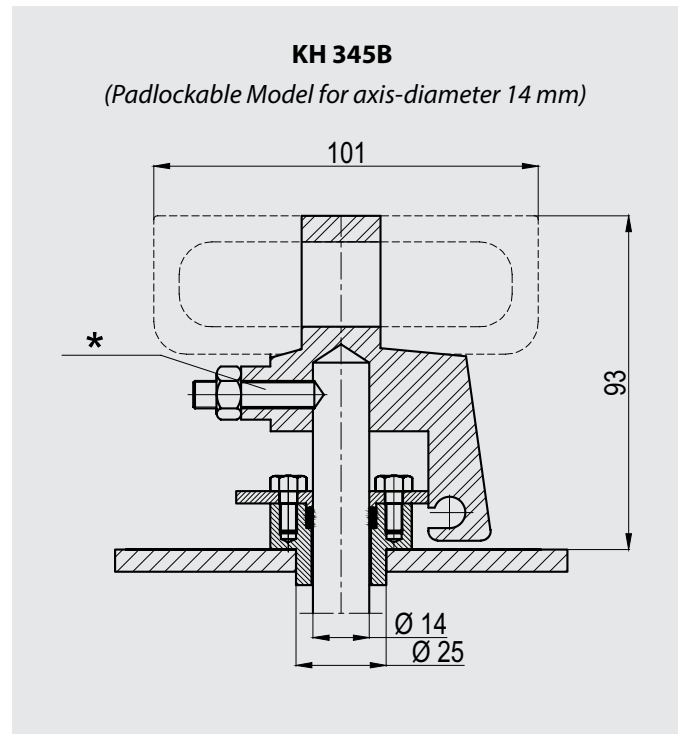
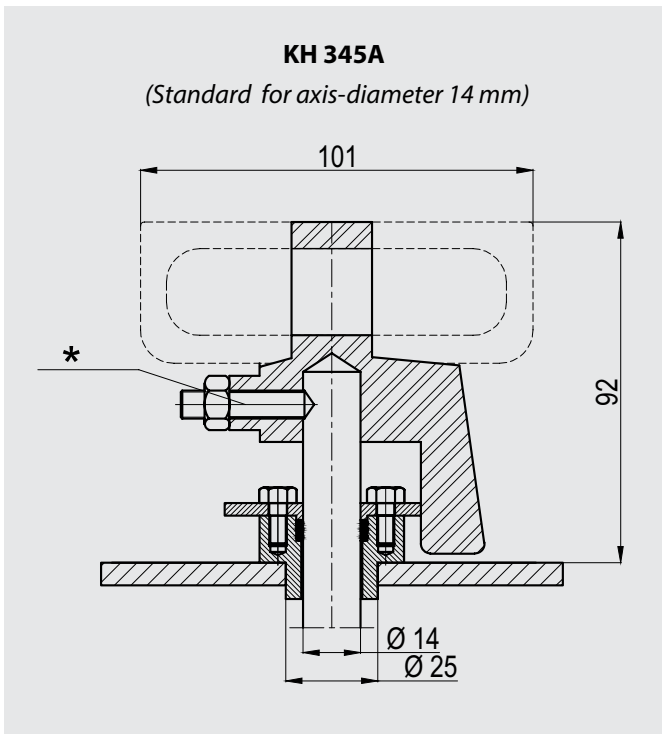

* the hole on the shaft is drilled at parallel position with respect to the middle position of the tap changer

Type KHF II Threephase Tap Changer

Handwheel-operated Control Devices (KH 349 / 350) and with Protective Cover (KH 347 / 348)

KH 347

(with Padlockable Protective Cover /
axis-diameter 14 mm)

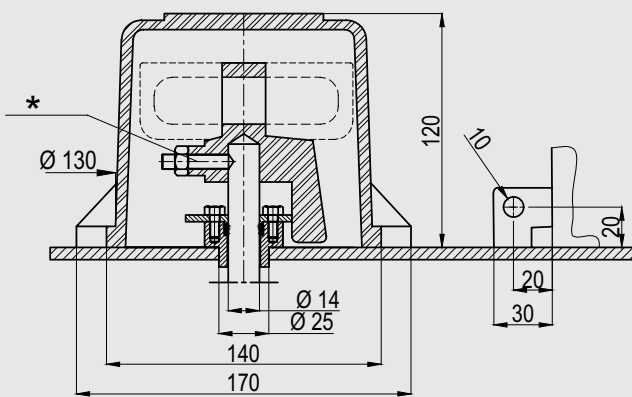

KH 348

(with Padlockable Protective Cover /
axis-diameter 20 mm)

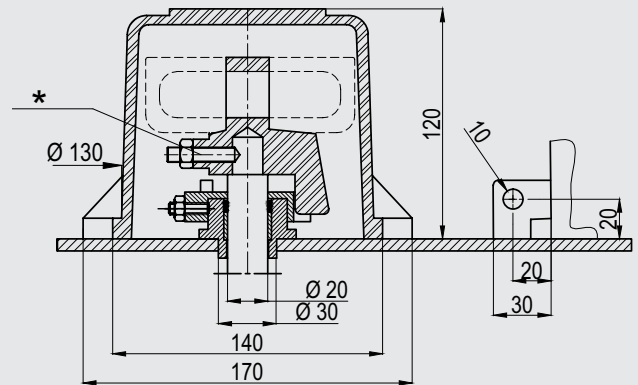

KH 349

(unlocking by padlockable pull knob /
for axis-diameter 20 mm)

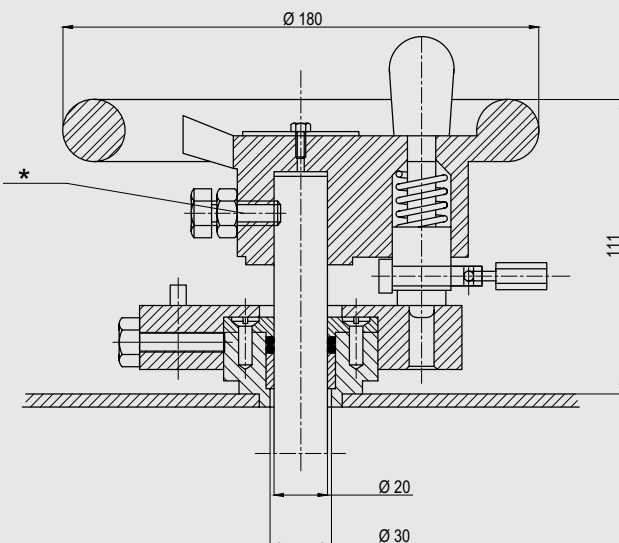

KH 350

(unlocking by axial displacement of the control shaft /
for axis-diameter 14 mm)

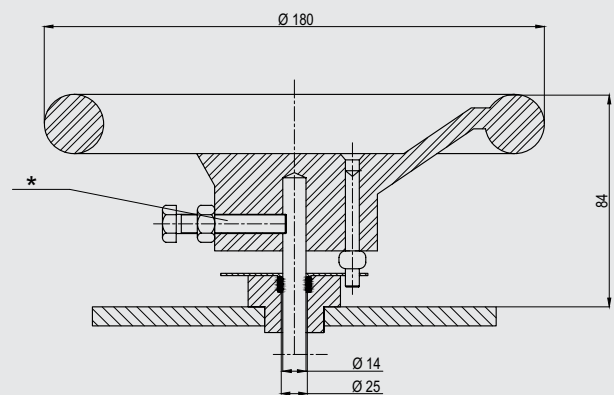

* the hole on the shaft is drilled at parallel position with respect to the middle position of the tap changer

Type KHF II Threephase Tap Changer

Fixed Contacts

Flag type contacts

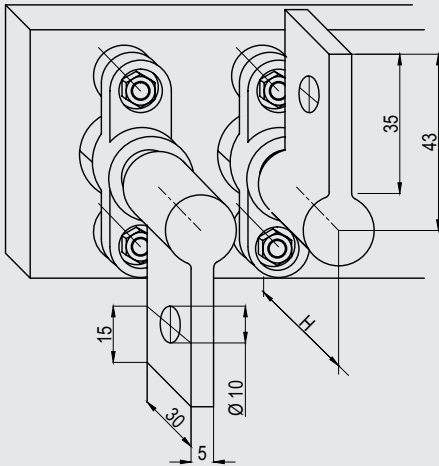

Tubular contacts

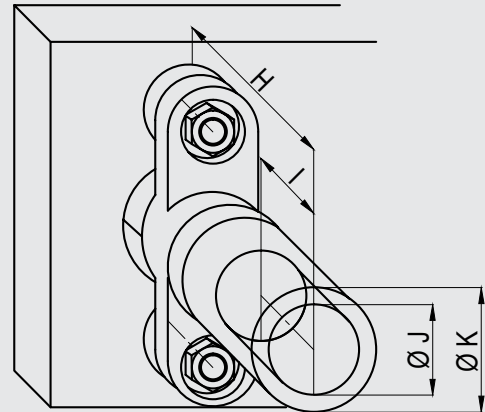

Fixed contact adapter for cable connection

(Optional for contact No : KH 374)

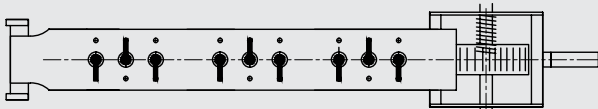
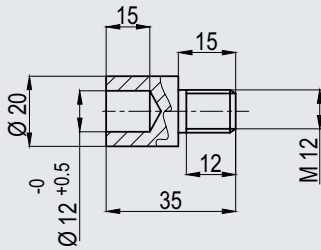

Unless otherwise specified by the customer, flag type contacts are positioned as in the diagram above. The contact situated near the operating device is facing downwards.

KH 371

Common contact with straight flat shape

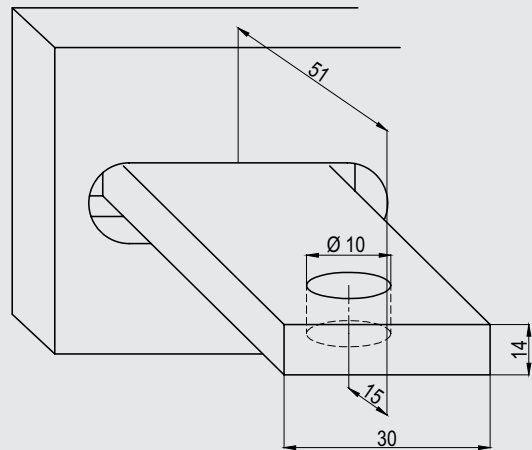

	Contact Numbers	Ø J	Ø K	I	H
150 A / Tubular Contact	KH 365	7	14	20	37
220 A / Tubular Contact	KH 366	8,5	14	20	37
150 A / Tubular Contact	KH 367	9,5	13,5	30	56
220 A / Tubular Contact	KH 368	13,5	17,4	30	56
315 A / Tubular Contact	KH 369	15,2	20	30	56
315 A / Tubular Contact (optional)	KH 372	M12	20	30	56
400 A / Flag Type	KH 370	-	30 x 30 x 5		51

Type KHF II Threephase Tap Changer

Handle Directions

Repeaters for rack and pinion operating controls

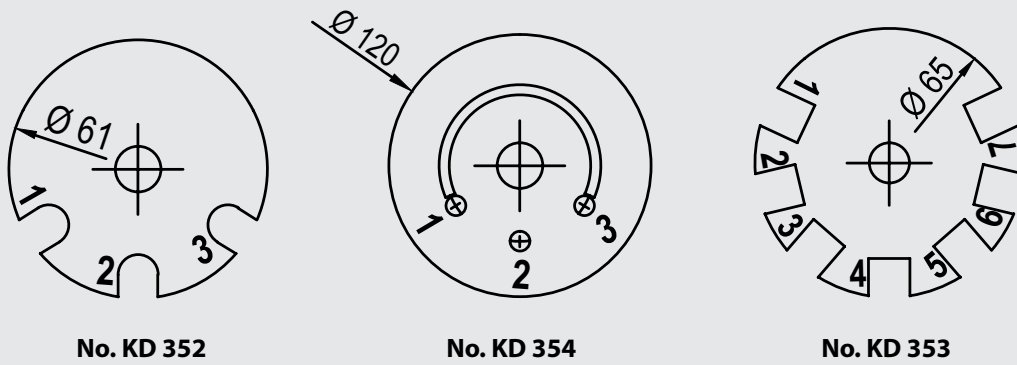

Numbering for repeaters for rack and pinion operating controls

A1

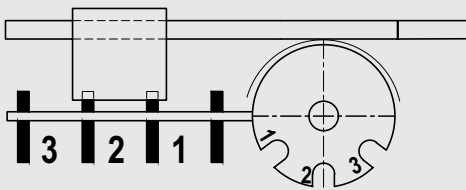

B1

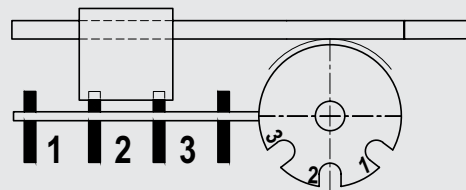

C1

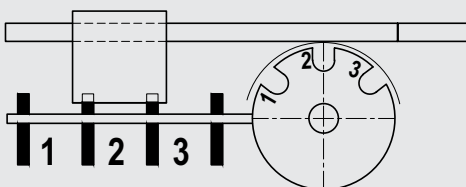

D1

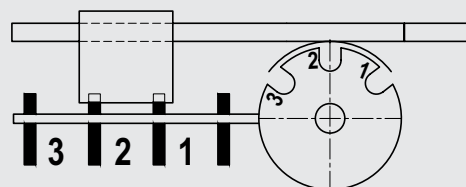

Type KHF II Threephase Tap Changer

Numbering Combinations

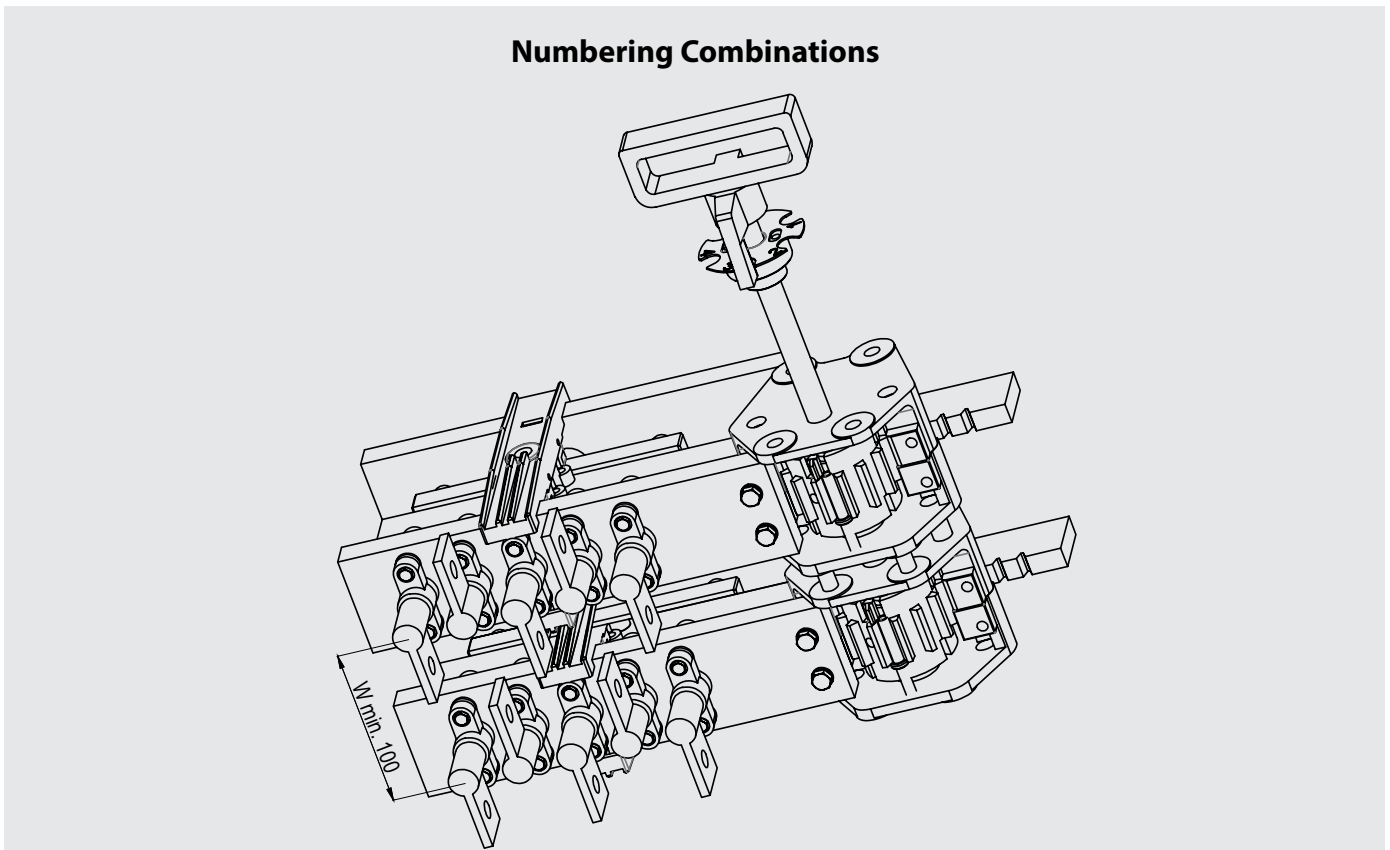

- all horizontal KHF II tap changers of the reinforced serie can be paired by superimposing several tap changers
- built steel brackets are assembled by nuts and bolts
- depending on which system is adopted, the user can:
 - either operate the tap changers with one shaft
 - or operate part of the tap changers with one shaft, and the other part with a second shaft
- the position of the coupling shaft and the position of the setting shaft has to be specified

Note: It is essential, when ordering, to quote dimension „W“ the minimum value of which to be set in each case depends on the insulation conditions and on the position of the different tap changers

Type KHF II Threephase Tap Changer

Numbering Combinations

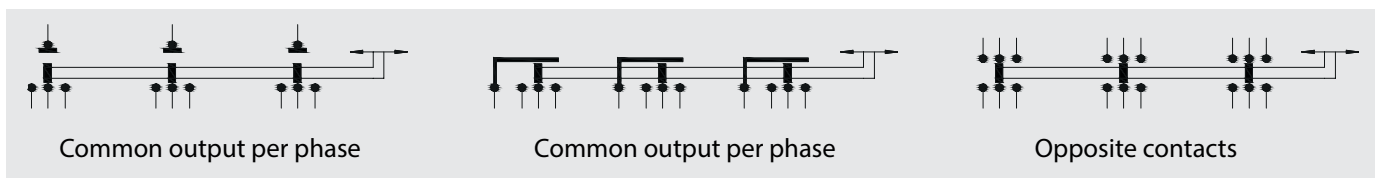
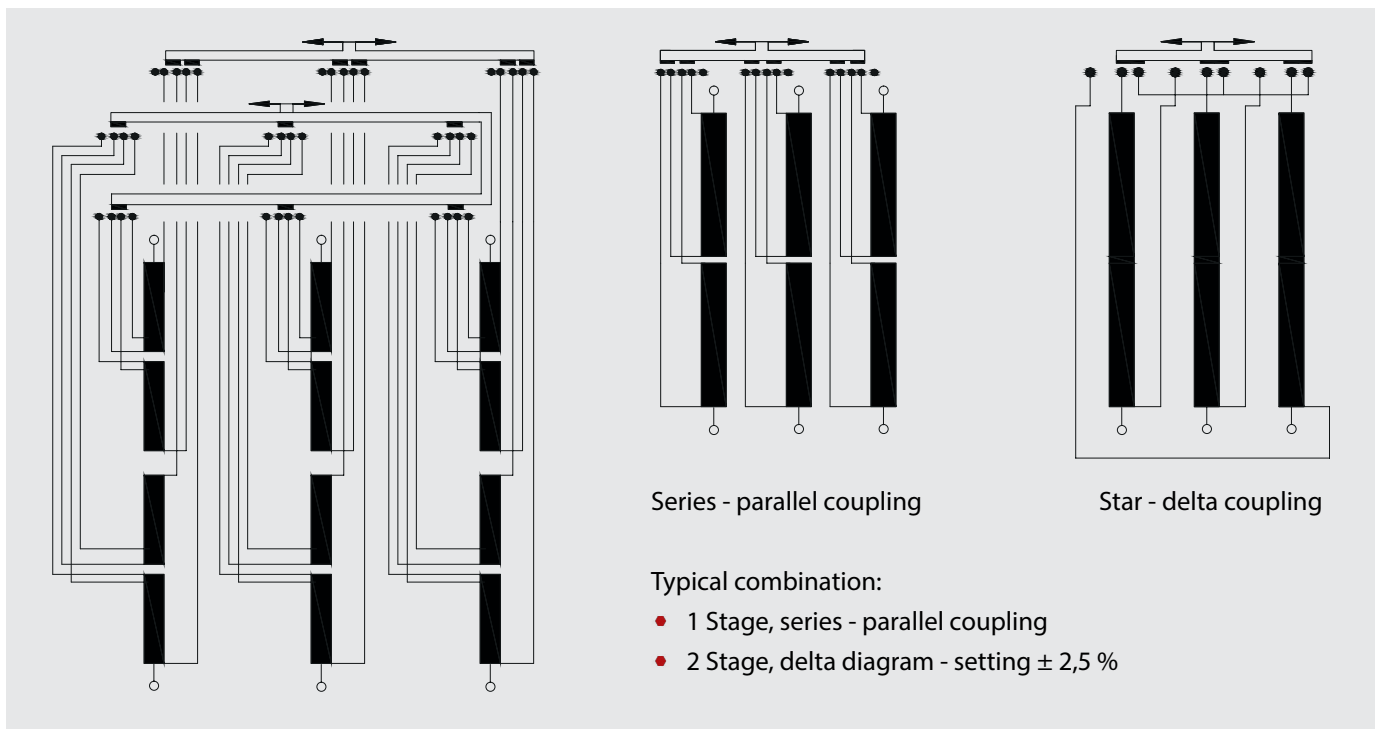
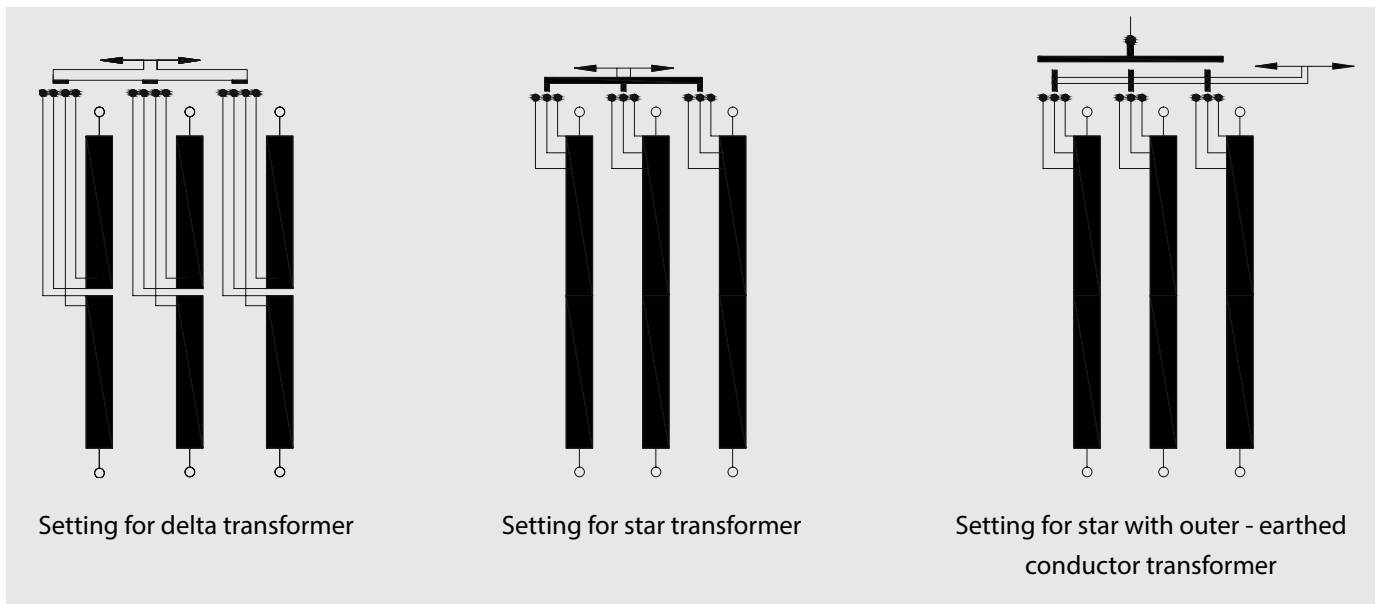

Type KHF II Threephase Tap Changer

Delta Diagram / 20 - 60 kV / 150 - 400 A / 2 - 6 Positions / Setting 2.5 % per Position (With Aluminium Support)

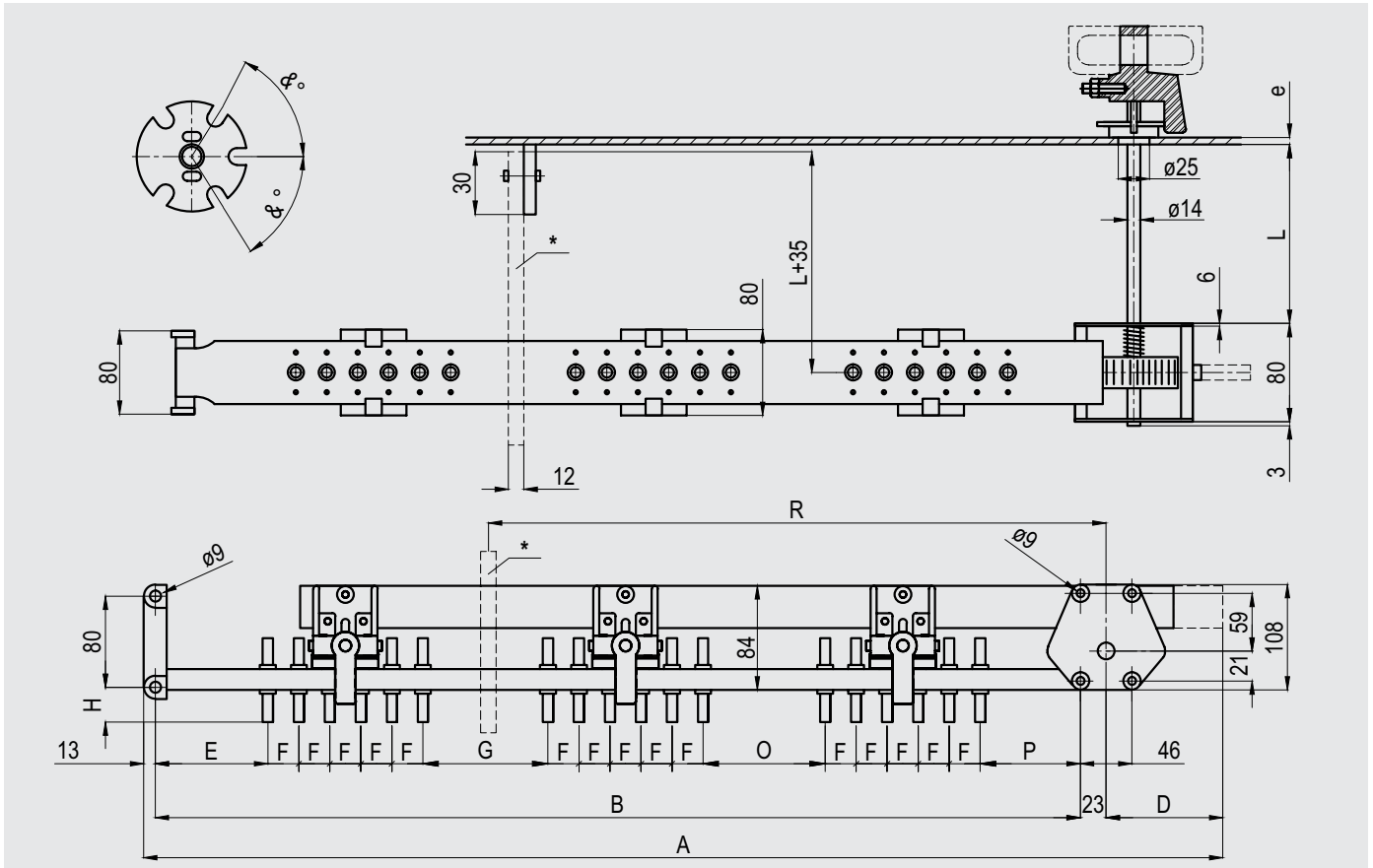

Voltage Class kV	Number of Positions	A	B	D	E	F	G	H	O	P	R	&°	L	e	Unit No
20	2	601	503	62	76	32	70	Depends on fixed contacts	70	95	351	63°	Please specify when ordering		M431D246
	3	729	599	94	76	32	70		70	95	415	63°		M431D346	
	4	857	695	126	76	32	70		70	95	479	63°		M431D446	
	5	985	791	158	76	32	70		70	95	543	63°		M431D546	
	6	1113	887	190	76	32	70		70	95	607	63°		M431D646	
30	2	721	623	62	106	32	100		100	125	426	63°		M431D256	
	3	849	719	94	106	32	100		100	125	490	63°		M431D356	
	4	977	815	126	106	32	100		100	125	554	63°		M431D456	
	5	1105	911	158	106	32	100		100	125	618	63°		M431D556	
	6	1233	1007	190	106	32	100		100	125	682	63°		M431D656	
60	2	1440	1331	73	267	43	260		260	286	871	84°		M431D266	
	3	1612	1460	116	267	43	260		260	286	957	84°		M431D366	
	4*	1784	1589	159	267	43	260		260	286	1043	84°		M431D466	
	5*	1956	1718	202	267	43	260		260	286	1129	81°		M431D566x	

* additional supporting plate is used

Type KHF II Threephase Tap Changer

Delta Diagram / 20 - 60 kV / 150 - 400 A / 7 - 9 Positions / Setting 2.5 % per Position (With Aluminium Support)

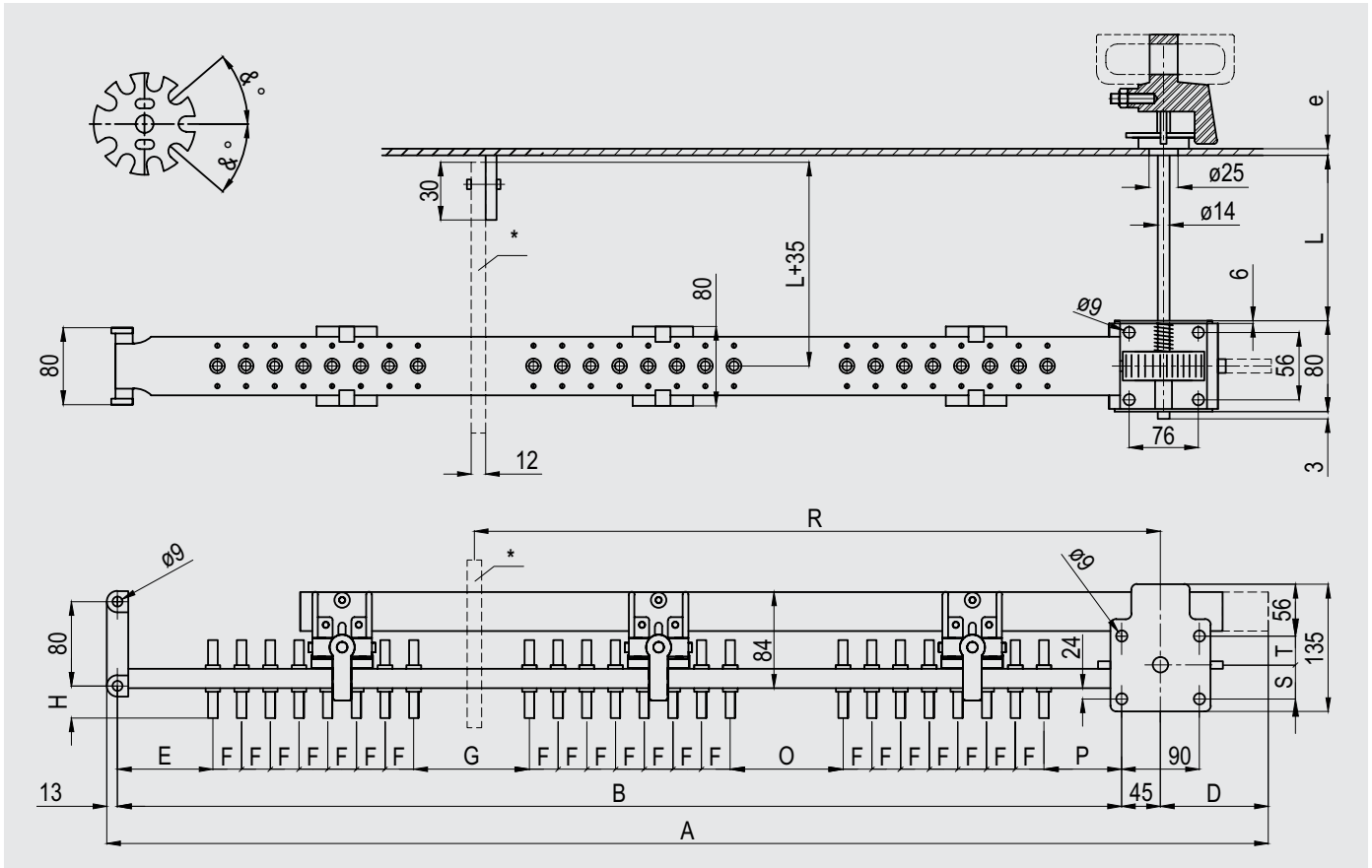

Voltage Class kV	Number of Positions	A	B	D	E	F	G	H	O	P	R	S	T	&°	L	e	Unit No
20	7	1263	983	222	76	32	70	Depends on fixed contacts	70	95	693	29	35	38°	Please specify when ordering		M431D746
	8	1391	1079	254	76	32	70		70	95	757	29	35	38°			M431D846
	9	1519	1175	286	76	32	70		70	95	821	29	35	38°			M431D946
30	7	1383	1103	222	106	32	100		100	125	768	29	35	38°			M431D756
	8	1511	1199	254	106	32	100		100	125	832	29	35	38°			M431D856
	9	1639	1295	286	106	32	100		100	125	896	29	35	38°			M431D956
60	6*	2150	1847	245	267	43	260		260	286	1237	29	35	51°			M431D666
	7*	2322	1976	288	267	43	260		260	286	1323	29	35	51°			M431D766

* additional supporting plate is used

Type KHF II Threephase Tap Changer

Delta Diagram / 20 - 60 kV / 150 - 400 A / 2 - 6 Positions / Setting 2.5 % per Position (With HP Support)

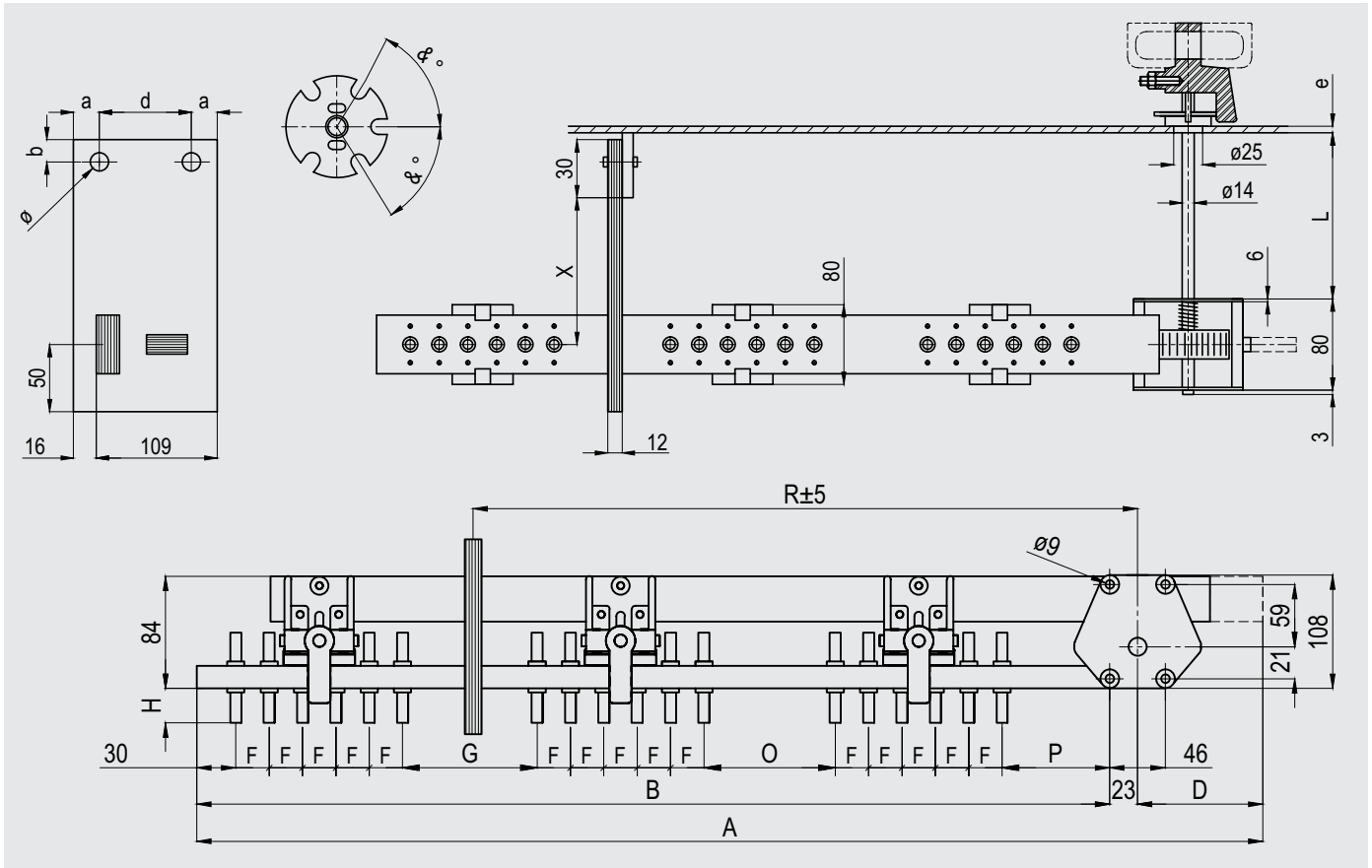

Voltage Class kV	Number of Positions	A	B	D	F	G	H	O	P	R	X min	α°	L	e	Unit No
20	2	542	457	62	32	70	Depends on fixed contacts	70	95	351	70	63°	Please specify when ordering		M433D246
	3	670	553	94	32	70		70	95	415	70	63°		M433D346	
	4	798	649	126	32	70		70	95	479	70	63°		M433D446	
	5	926	745	158	32	70		70	95	543	70	63°		M433D546	
	6	1054	841	190	32	70		70	95	607	70	63°		M433D646	
30	2	632	547	62	32	100		100	125	426	130	63°		M433D246	
	3	760	643	94	32	100		100	125	490	130	63°		M433D356	
	4	888	739	126	32	100		100	125	554	130	63°		M433D456	
	5	1016	835	158	32	100		100	125	618	130	63°		M433D556	
	6	1144	931	190	32	100		100	125	682	130	63°		M433D656	
60	2	1190	1094	73	43	260		260	286	871	250	84°		M433D266	
	3	1362	1223	116	43	260		260	286	957	250	84°		M433D366	
	4	1534	1352	159	43	260		260	286	1043	250	84°		M433D466	
	5	1706	1481	202	43	260		260	286	1129	250	81°		M433D566	

Type KHF II Threephase Tap Changer

Delta Diagram / 20 - 60 kV / 150 - 400 A / 7 - 9 Positions / Setting 2.5 % per Position (With HP Support)

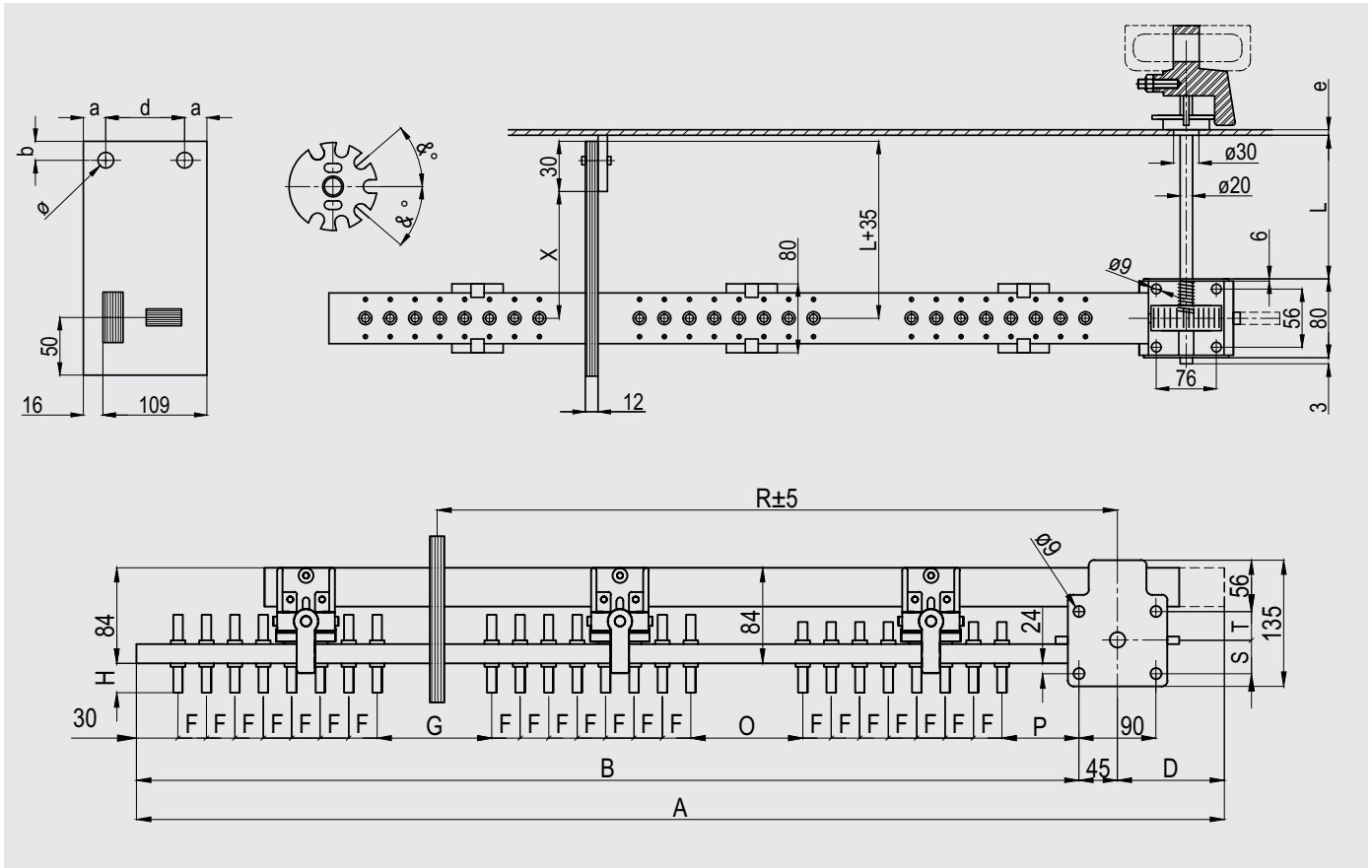

Voltage Class kV	Number of Positions	A	B	D	F	G	H	O	P	R	S	T	X min	&°	L	e	Unit No
20	7	1204	937	222	32	70	Depends on fixed contacts	70	95	693	29	35	70	38°	Please specify when ordering		M433D746
	8	1332	1033	254	32	70		70	95	757	29	35	70	38°			M433D846
	9	1460	1129	286	32	70		70	95	821	29	35	70	38°			M433D946
30	7	1294	1027	222	32	100		100	125	768	29	35	130	38°		M433D756	
	8	1422	1123	254	32	100		100	125	832	29	35	130	38°		M433D856	
	9	1550	1219	286	32	100		100	125	896	29	35	130	38°		M433D956	
60	6	1900	1610	245	43	260		260	286	1237	29	35	250	51°		M433D666	
	7	2072	1739	288	43	260		260	286	1323	29	35	250	51°		M433D766	

Type KHF II Threephase Tap Changer

Delta Diagram / 20 - 30 kV / 150 - 400 A / 10 - 11 Positions / Setting 2.5 % per Position
(with Aluminium Support)

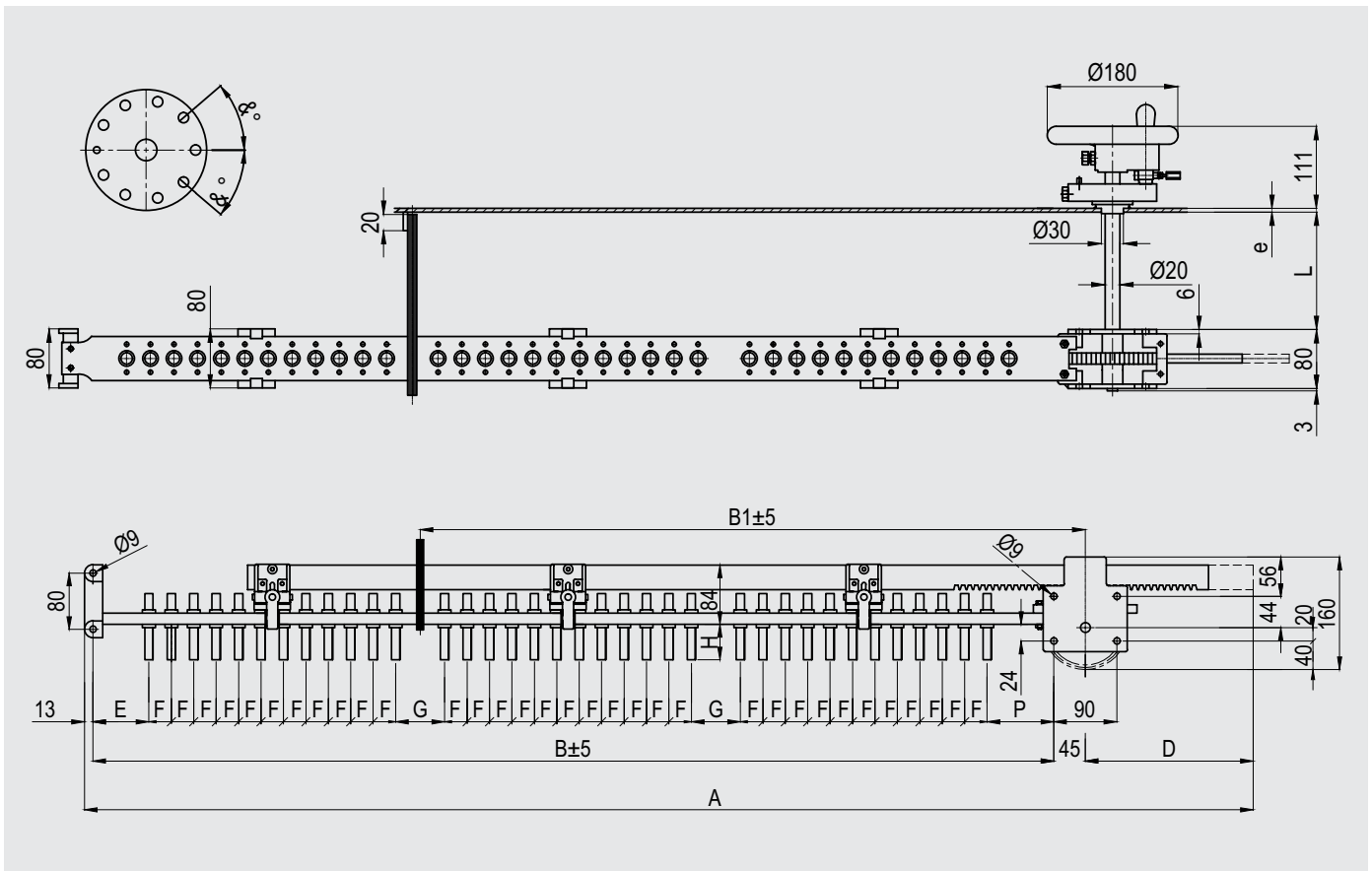

Voltage Class kV	Number of Positions	A	B	B1	D	F	E	H	G	P	S	T	&°	L	e	Unit No
20	10	1661	1271	885	332	32	76	Depends on fixed contacts	70	95	20	44	32°	Please specify when ordering		M431D1046
	11	1789	1367	949	364	32	76		70	95	20	44	32°			M431D1146
30	10	1781	1391	960	332	32	106	Depends on fixed contacts	100	125	20	44	32°			M431D1056
	11	1909	1487	1024	364	32	106		100	125	20	44	32°			

Type KHF II Threephase Tap Changer

Delta Diagram / 20 - 30 kV / 150 - 400 A / 7 - 11 Positions / Setting 2.5 % per Position
(with Aluminium Support)

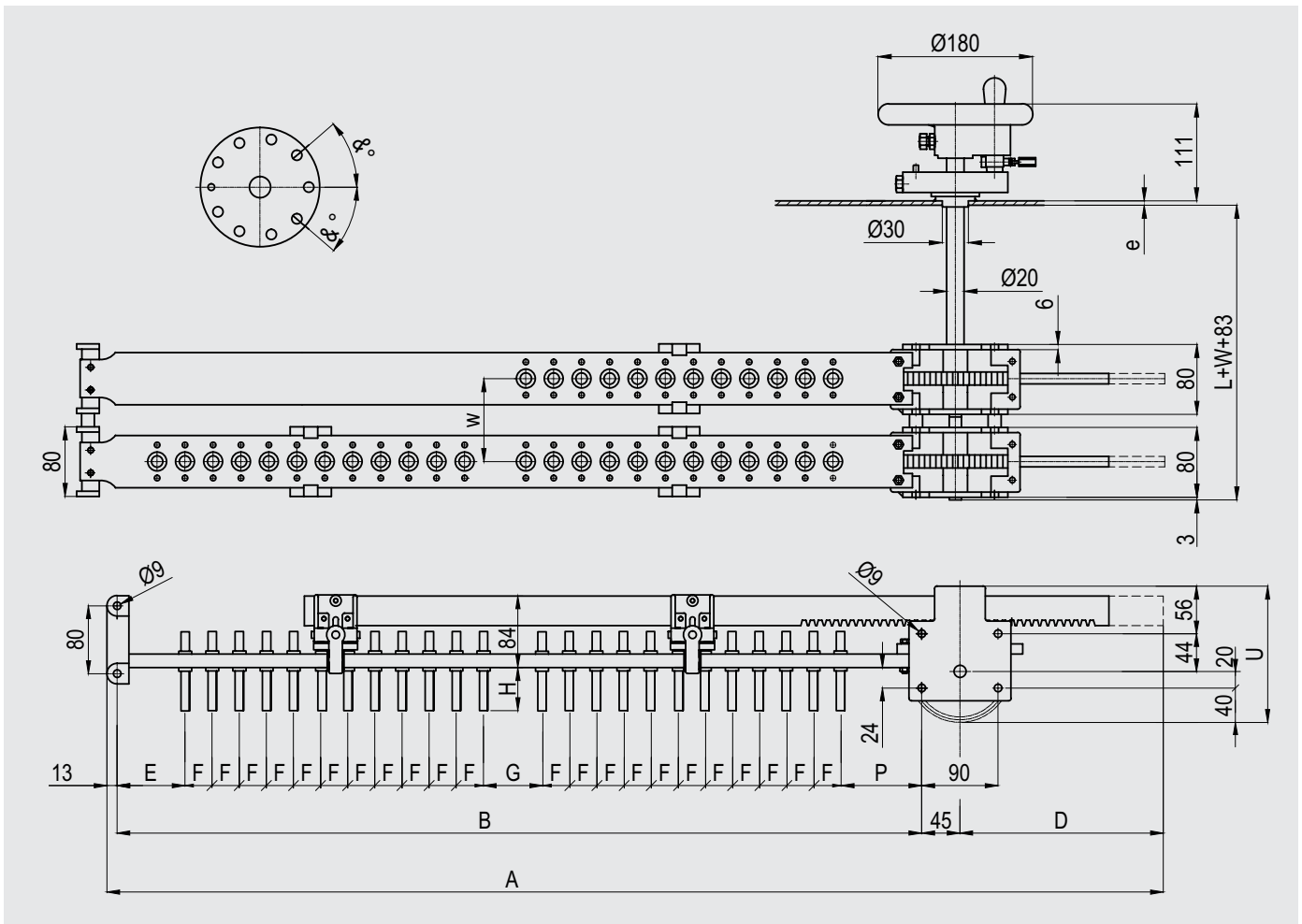

Voltage Class kV	Number of Positions	A	B	D	F	E	H	G	P	S	T	U	&°	L	e	Unit No
20	7	969	689	222	32	76	Depends on fixed contacts	70	95	29	35	151	38°	Please specify when ordering		M471D746
	8	1065	753	254	32	76		70	95	29	35	151	38°			M471D846
	9	1161	817	286	32	76		70	95	29	35	151	38°			M471D946
	10	1271	881	332	32	76		70	95	20	44	160	32°			M471D1046
	11	1367	945	364	32	76		70	95	20	44	160	32°			M471D1146
30	7	1059	779	222	32	106	Depends on fixed contacts	100	125	29	35	151	38°	Please specify when ordering		M471D756
	8	1155	843	254	32	106		100	125	29	35	151	38°			M471D856
	9	1251	907	286	32	106		100	125	29	35	151	38°			M471D956
	10	1361	971	332	32	106		100	125	20	44	160	32°			M471D1056
	11	1457	1035	364	32	106		100	125	20	44	160	32°			M471D1156

Type KHF II Threephase Tap Changer

Delta Diagram / 20 - 30 kV / 150 - 400 A / 7 - 11 Positions / Setting 2.5 % per Position
(with Aluminium Support)

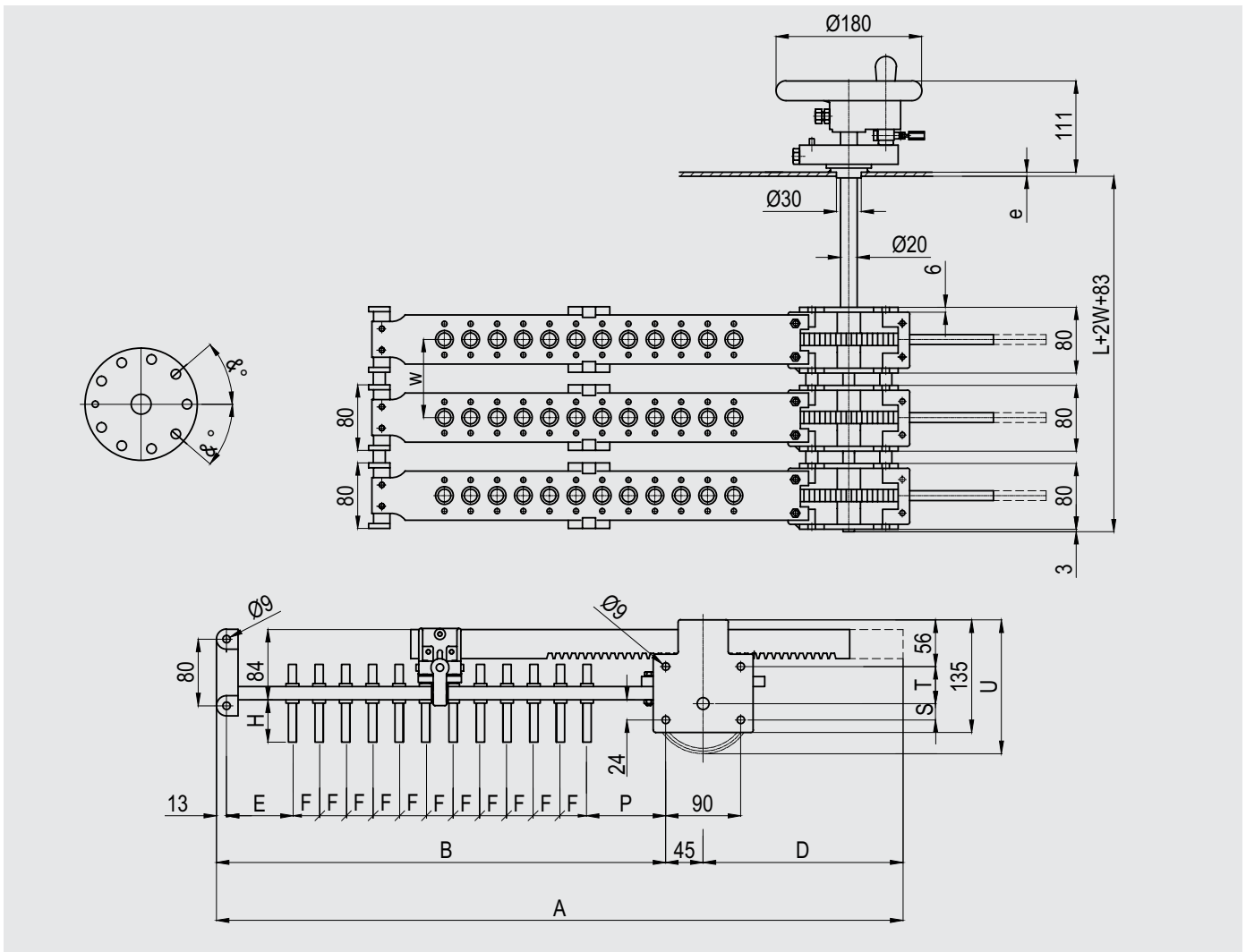

Voltage Class kV	Number of Positions	A	B	D	F	E	H	P	S	T	U	& °	L	e	W	Unit No
20	7	675	395	222	32	76	Depends on fixed contacts	95	29	35	151	38 °	Please specify when ordering			M481D746
	8	739	427	254	32	76		95	29	35	151	38 °				M481D846
	9	803	459	286	32	76		95	29	35	151	38 °				M481D946
	10	881	491	332	32	76		95	20	44	160	32 °				M481D1046
	11	945	523	364	32	76		95	20	44	160	32 °				M481D1146
30	7	735	455	222	32	106	Depends on fixed contacts	125	29	35	151	38 °	Please specify when ordering			M481D756
	8	799	487	254	32	106		125	29	35	151	38 °				M481D856
	9	863	519	286	32	106		125	29	35	151	38 °				M481D956
	10	941	551	332	32	106		125	20	44	160	32 °				M481D1056
	11	1005	583	364	32	106		125	20	44	160	32 °				M481D1156

Type KHF II Threephase Tap Changer

Delta Diagram / 20 - 60 kV / 150 - 400 A / 2 - 6 Positions / Setting 2.5 % per Position
(with Aluminium Support)

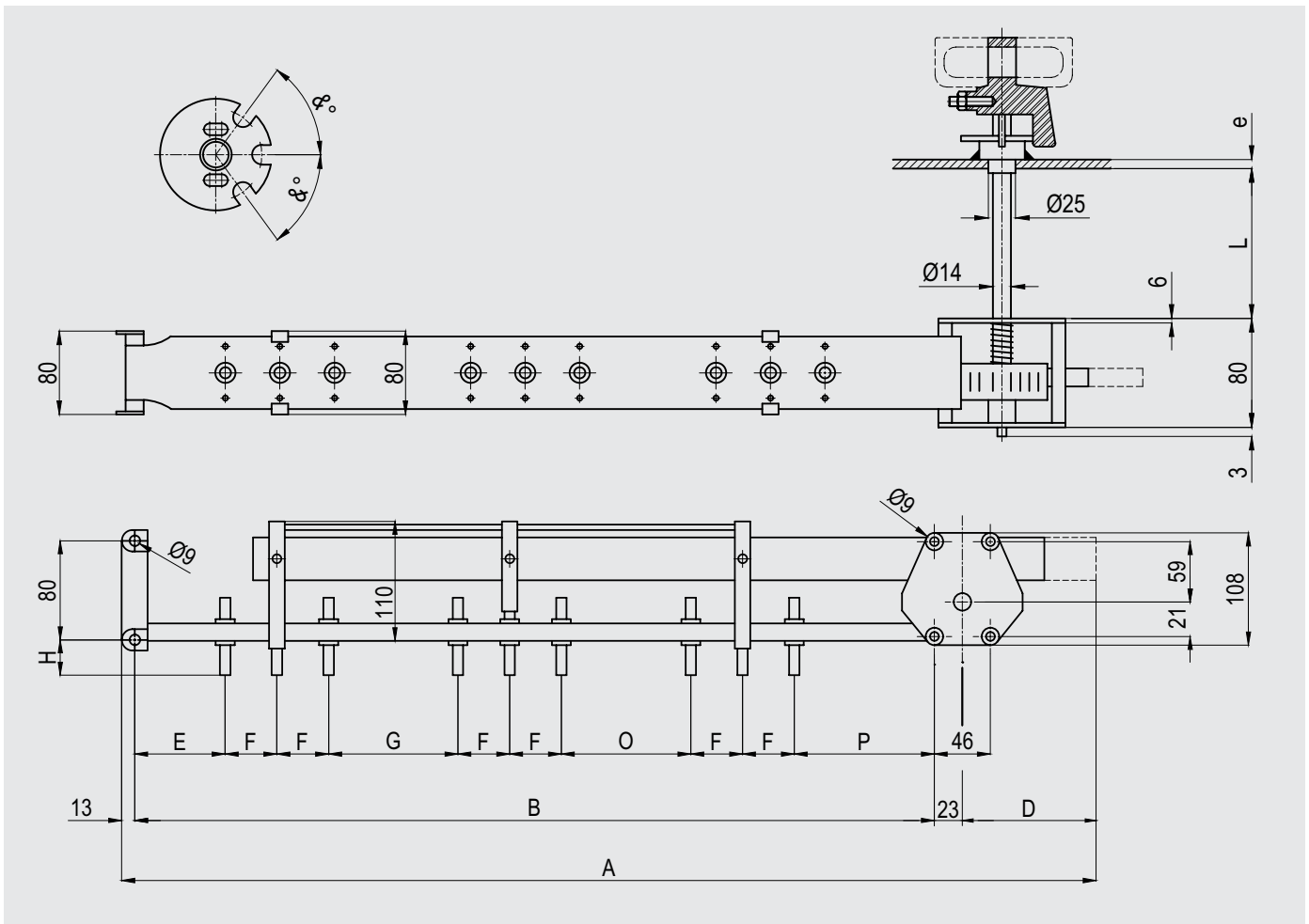

Voltage Class kV	Number of Positions	A	B	D	F	E	G	H	P	O	α°	L	e	Unit No
20	2	429	331	62	32	76	32	Depends on fixed contacts	95	32	63°	Please specify when ordering		M431S246
	3	557	427	94	32	76	32		95	32	63°			M431S346
	4	685	523	126	32	76	32		95	32	63°			M431S446
	5	813	619	158	32	76	32		95	32	63°			M431S546
	6	941	715	190	32	76	32		95	32	63°			M431S646
30	2	489	391	62	32	106	32		125	29	63°		M431S256	
	3	617	487	94	32	106	32		125	29	63°		M431S356	
	4	745	583	126	32	106	32		125	29	63°		M431S456	
	5	873	679	158	32	106	32		125	20	63°		M431S556	
	6	1001	775	190	32	106	32		125	20	63°		M431S656	
60	2	931	822	73	43	267	70	286	70	84°	M431S266			
	3	1103	951	116	43	267	70	286	70	84°	M431S366			
	4	1275	1080	159	43	267	70	286	70	84°	M431S466			
	5	1447	1209	202	43	267	70	286	70	81°	M431S466			
												M431S566		

Type KHF II Threephase Tap Changer

Star Diagram / 20 - 60 kV / 150 - 400 A / 7 - 9 Positions / Setting 2.5 % per Position
(with Aluminium Support)

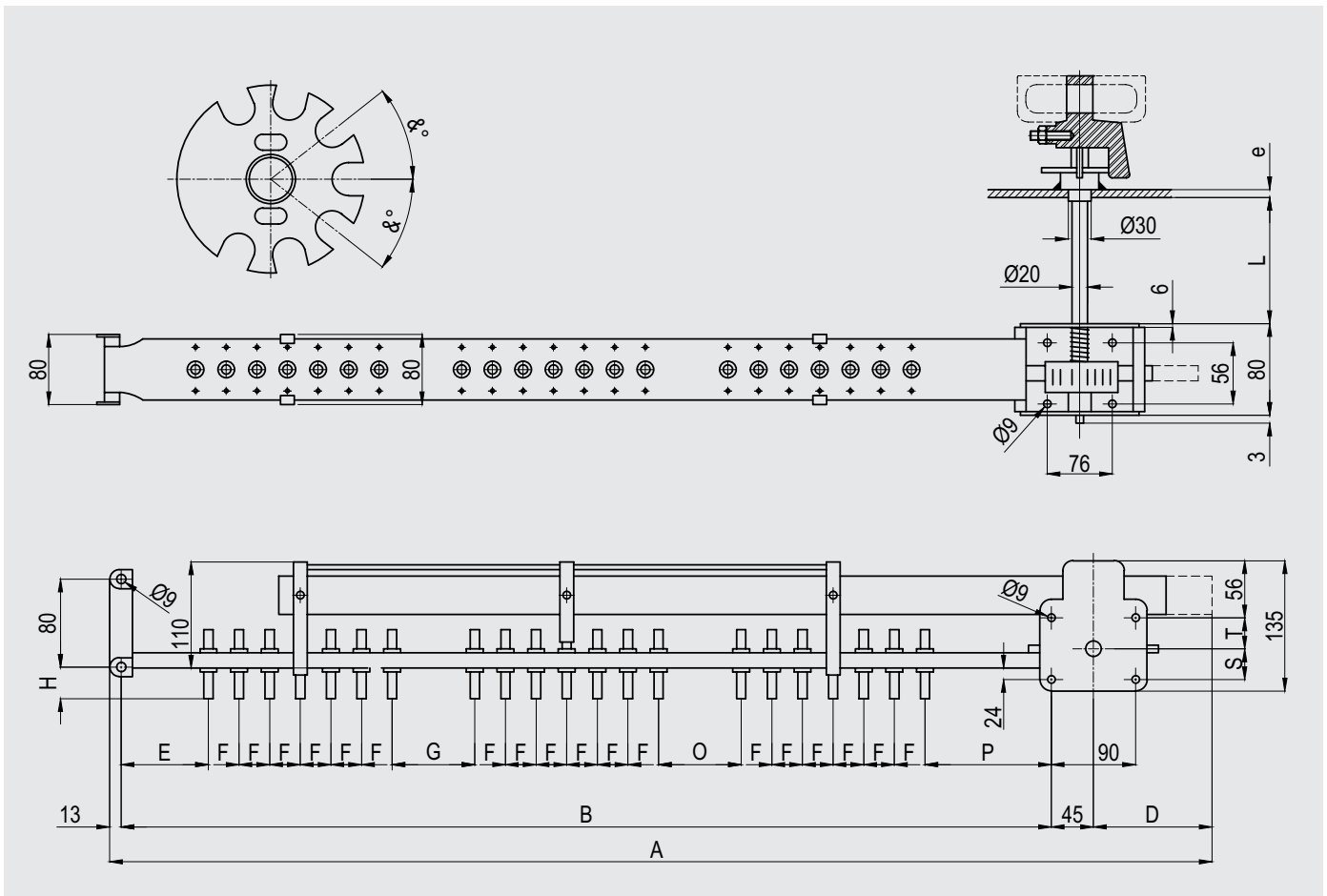

Voltage Class kV	Number of Positions	A	B	D	F	E	G	H	P	O	S	T	& °	L	e	Unit No
20	7	1091	811	222	32	76	32	Depends on fixed contacts	95	32	29	35	38°	Please specify when ordering		431S746
	8	1219	907	254	32	76	32		95	32	29	35	38°			431S846
	9	1347	1003	286	32	76	32		95	32	29	35	38°			431S946
30	7	1151	871	222	32	106	32		125	32	29	35	38°			431S756
	8	1279	967	254	32	106	32		125	32	29	35	38°			431S856
	9	1407	1063	286	32	106	32		125	32	29	35	38°			431S956
60	6	1641	1338	245	43	267	70		286	70	29	35	51°			431S666
	7	1813	1467	288	43	267	70		286	70	29	35	51°			431S766

Type KHF II Threephase Tap Changer

Star Diagram / 20 - 60 kV / 150 - 400 A / 2 - 6 Positions / Setting 2.5 % per Position
(with Aluminium Support)

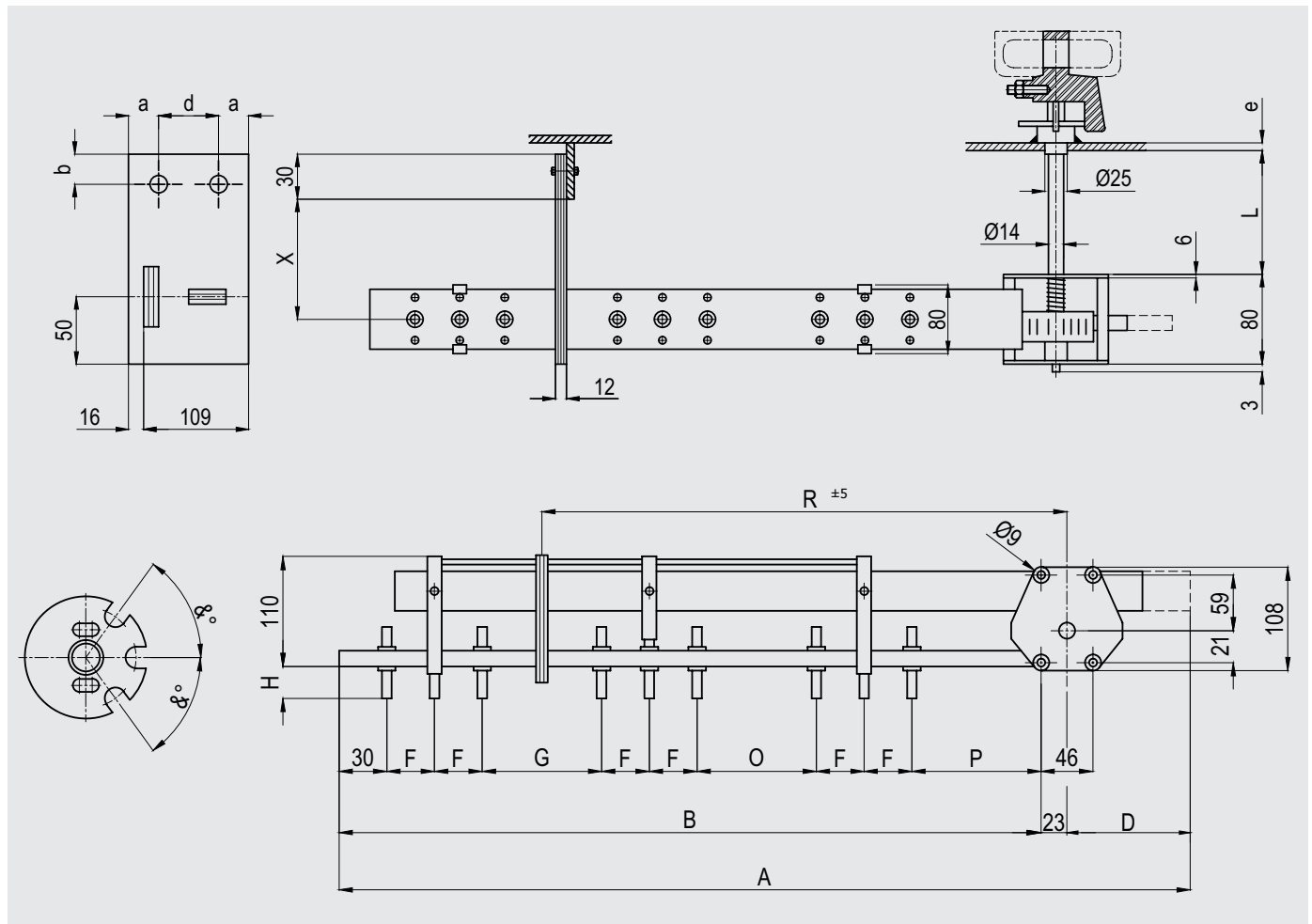

Voltage Class kV	Number of Positions	A	B	D	F	G	H	O	P	R	X min	8°	L	e	Unit No
20	2	398	313	62	32	60	Depends on fixed contacts	32	95	244	70	63°	Please specify when ordering		M433S246
	3	526	409	94	32	60		32	95	308	70	63°			M433S346
	4	654	505	126	32	60		32	95	372	70	63°			M433S446
	5	782	601	158	32	60		32	95	436	70	63°			M433S546
	6	910	697	190	32	60		32	95	500	70	63°			M433S646
	30	2	428	343	62	32		60	Depends on fixed contacts	32	125	274			130
3		556	439	94	32	60	32	125		338	130	63°	M433S356		
4		684	535	126	32	60	32	125		402	130	63°	M433S456		
5		812	631	158	32	60	32	125		466	130	63°	M433S556		
6		940	727	190	32	60	32	125		530	130	63°	M433S656		
60		2	681	585	73	43	70	Depends on fixed contacts		70	286	500	250	84°	Please specify when ordering
	3	853	714	116	43	70	70		286	586	250	84°	M433S366		
	4	1025	843	159	43	70	70		286	672	250	84°	M433S466		
	5	1197	972	202	43	70	70		286	758	250	81°	M433S566		

Type KHF II Threephase Tap Changer

Star Diagram / 20 - 60 kV / 150 - 400 A / 7 - 9 Positions / Setting 2.5 % per Position (with HP Support)

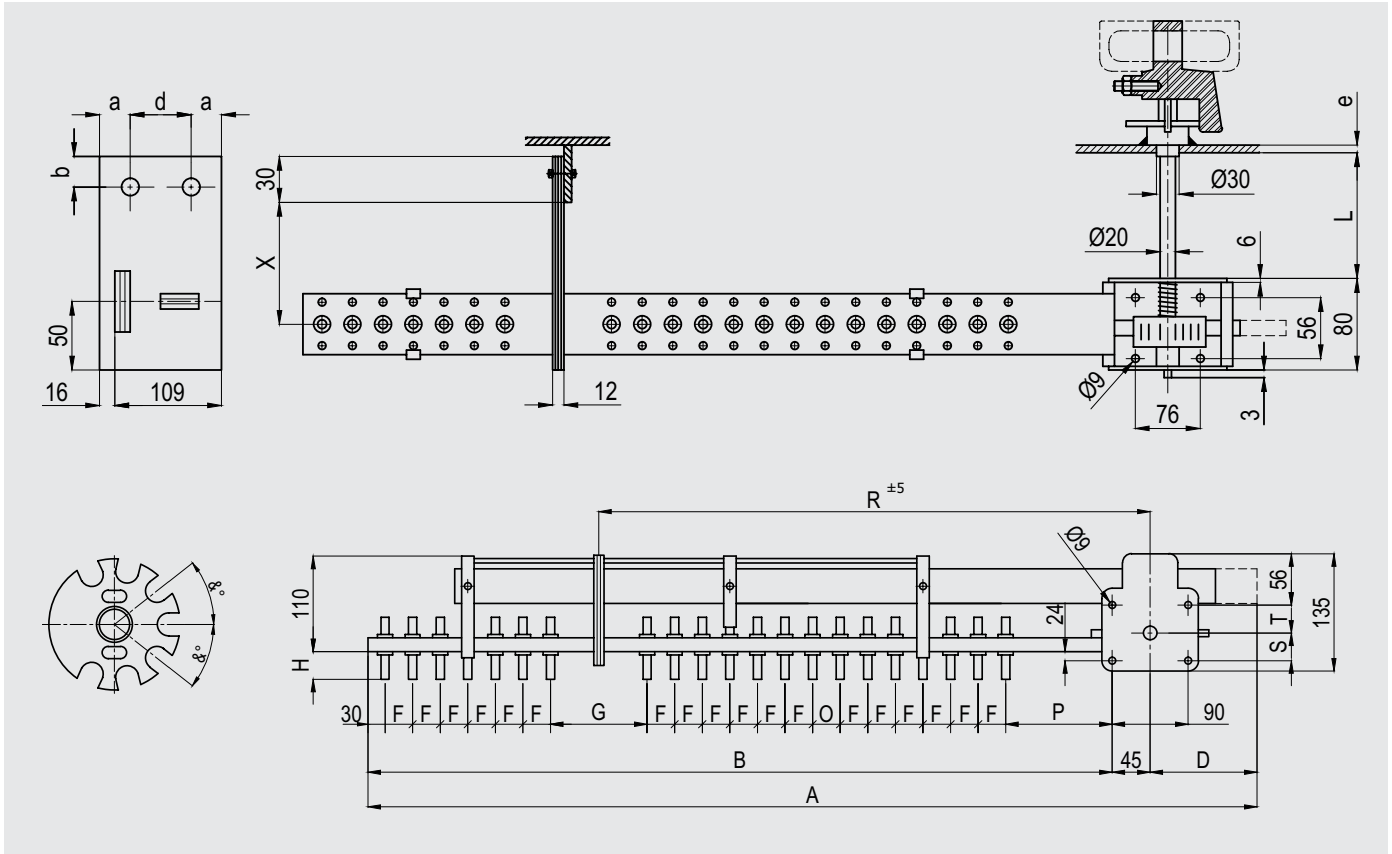

Voltage Class kV	Number of Positions	A	B	D	F	G	H	O	P	R	S	T	X min	&°	L	e	Unit No		
20	7	1060	793	222	32	60	Depends on fixed contacts	32	95	586	29	35	70	38°	Please specify when ordering		M433S746		
	8	1188	889	254	32	60		32	95	650	29	35	70	38°			M433S846		
	9	1316	985	286	32	60		32	95	714	29	35	70	38°			M433S946		
30	7	1090	823	222	32	60		32	125	616	29	35	130	38°			M433S756		
	8	1218	919	254	32	60		32	125	680	29	35	130	38°			M433S856		
	9	1346	1015	286	32	60		32	125	744	29	35	130	38°			M433S956		
60	6*	1391	1101	245	43	70		70	286	866	29	35	250	51°			Please specify when ordering		M433S666
	7*	1563	1230	288	43	70		70	286	952	29	35	250	51°					M433S766

Type KHF II Threephase Tap Changer

Series Parallel Coupling / 10 - 30 kV / 150 - 400 A (with Aluminium Support)

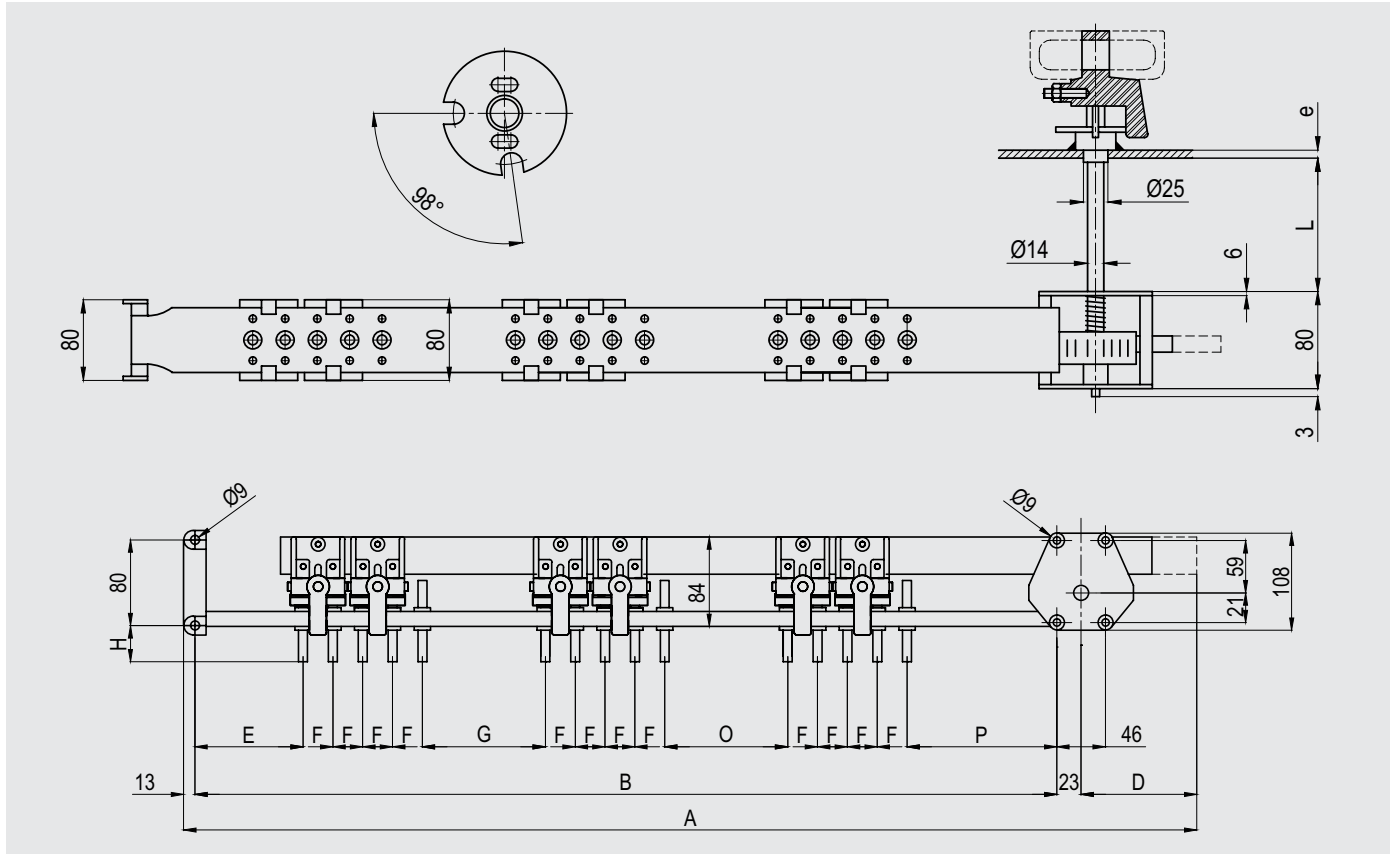

Voltage Class kV	A	B	D	E	F	G	H	O	P	&°	L	e	Unit No
10 - 20	1027	911	80	76	50	70	Depends on fixed contacts	70	95	98°	Please specify when ordering		M431P276
15 - 30	1227	1111	80	126	50	120		120	145	98°			M431P286

Type KHF II Threephase Tap Changer

Star Delta Coupling / 20 - 30 kV / 150 - 400 A (with Aluminium Support)

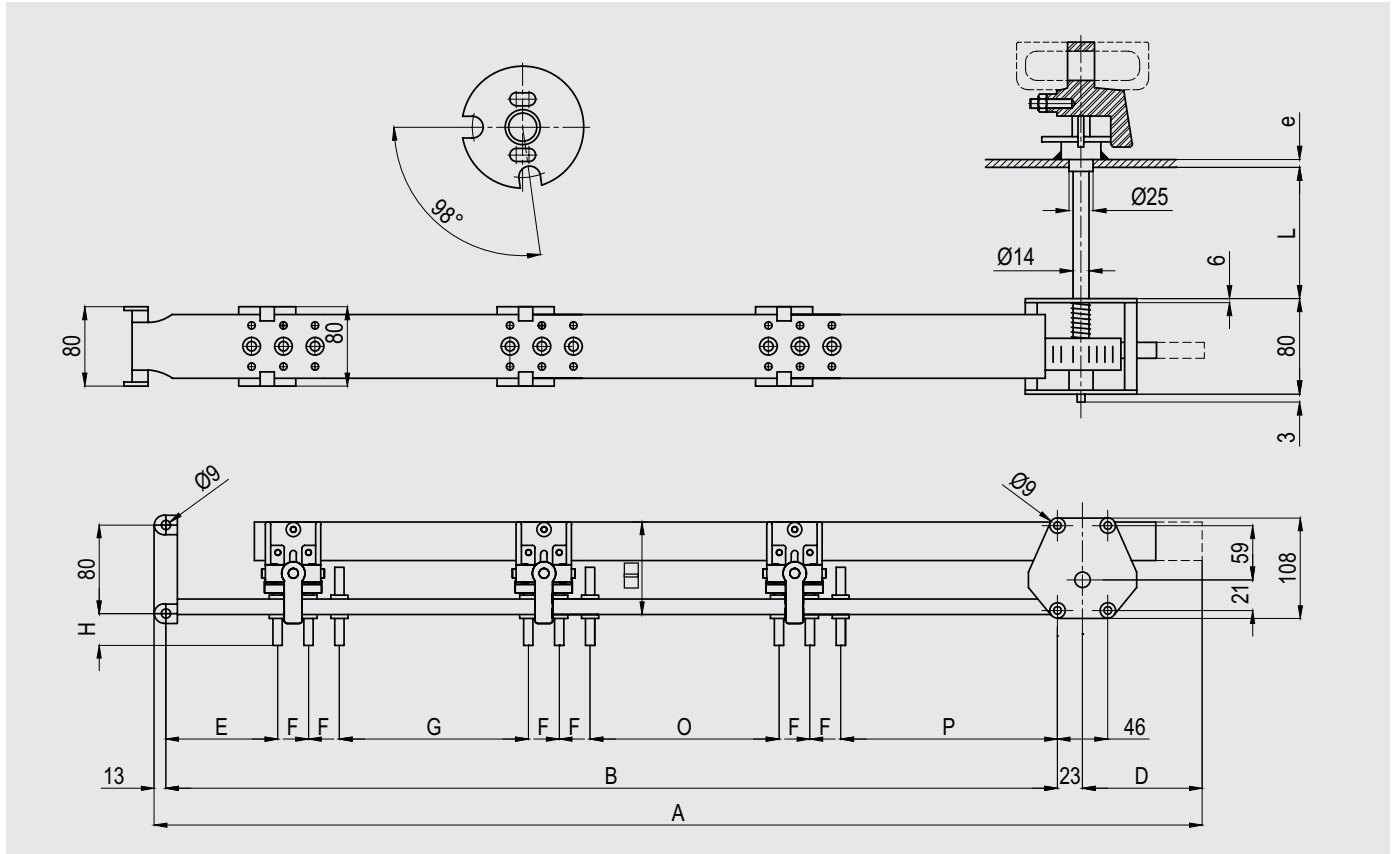

Voltage Class kV	A	B	D	E	F	G	H	O	P	&°	L	e	Unit No
20	727	611	80	76	50	70	Depends on fixed contacts	70	95	98°	Please specify when ordering		M431R246
30	1029	887	106	106	76	100		100	125	149°			M431R256

Type KHF II Threephase Tap Changer

Common Output per Phase / 20 - 60 kV / 150 - 400 A / 3 - 6 Positions / Setting 2.5 % per Position
(with Aluminium Support)

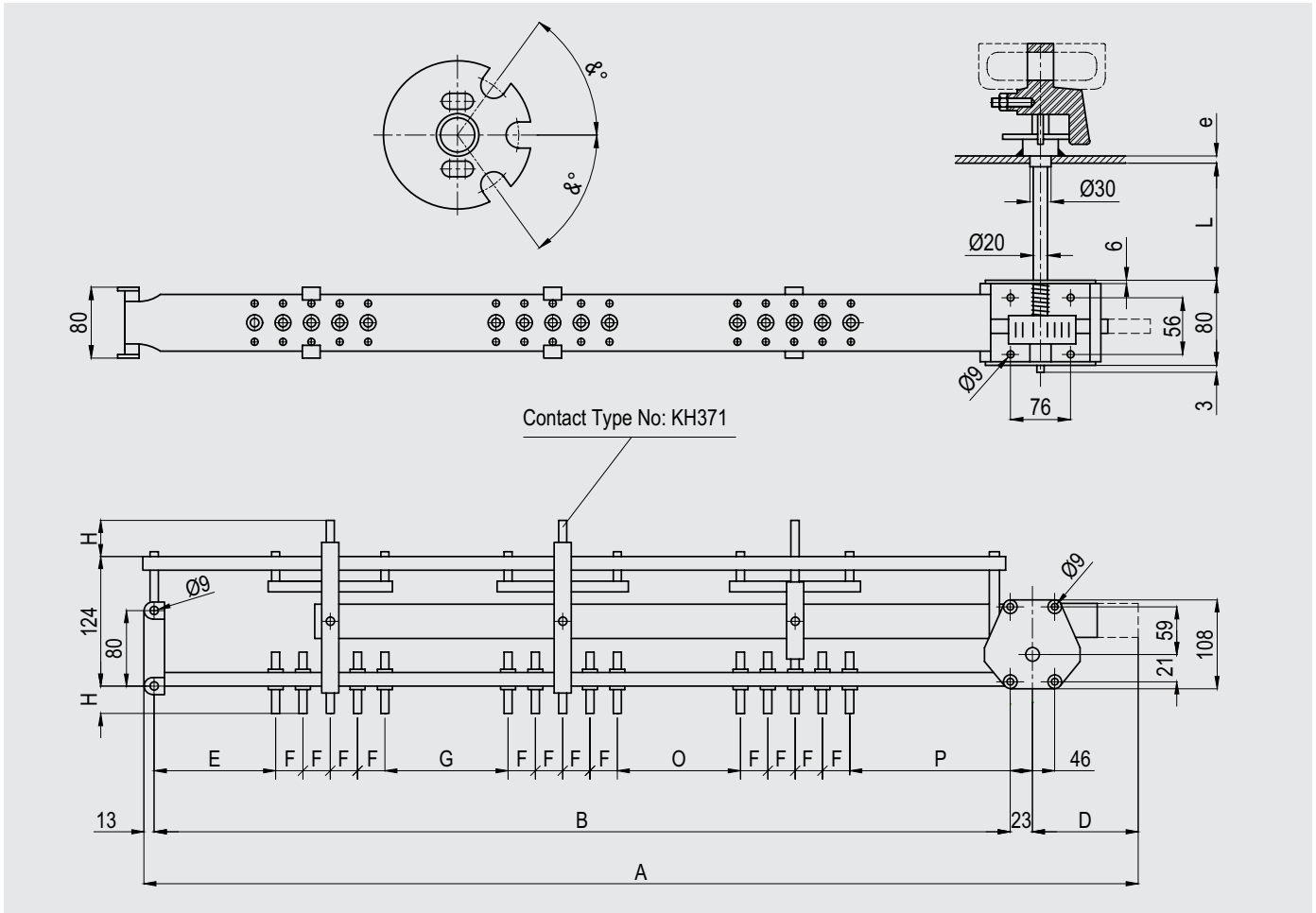

Voltage Class kV	Number of Positions	A	B	D	E	F	G	H	O	P	&°	L	e	Unit No
20	3	633	503	94	76	32	70	Depends on fixed contacts	70	95	63°	Please specify when ordering		M431C346
	4	761	599	126	76	32	70		70	95	63°			M431C446
	5	889	695	158	76	32	70		70	95	63°			M431C546
	6	1017	791	190	76	32	70		70	95	63°			M431C646
30	3	753	623	94	106	32	100		100	125	63°		M431C356	
	4	881	719	126	106	32	100		100	125	63°		M431C456	
	5	1009	815	158	106	32	100		100	125	63°		M431C556	
	6	1137	911	190	106	32	100		100	125	63°		M431C656	
60	3	1483	1331	116	267	43	260		260	286	84°		M431C466	
	4	1655	1460	159	267	43	260		260	286	84°		M431C566	
	5	1827	1589	202	267	43	260		260	286	81°		M431C666	

Type KHF II Threephase Tap Changer

Common Output per Phase / 20 - 60 kV / 150 - 400 A / 7 - 9 Positions / Setting 2.5 % per Position
(with Aluminium Support)

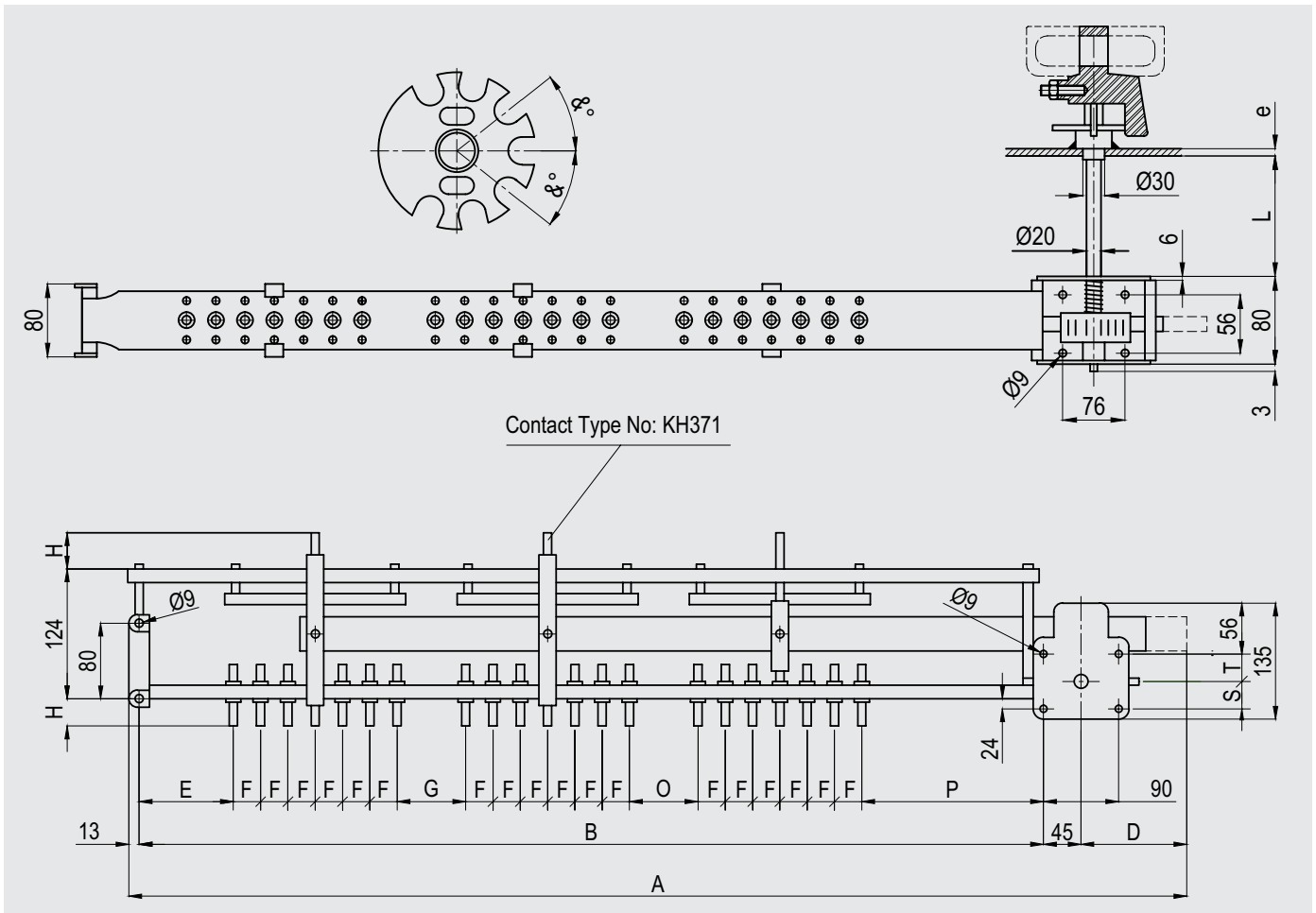

Voltage Class kV	Number of Positions	A	B	D	E	F	G	H	O	P	S	T	&°	L	e	Unit No
20	7	1167	887	222	76	32	70	Depends on fixed contacts	70	95	29	35	38°	Please specify when ordering		M431C746
	8	1295	983	254	76	32	70		70	95	29	35	38°			M431C846
	9	1423	1079	286	76	32	70		70	95	29	35	38°			M431C946
30	7	1287	1007	222	106	32	100		100	125	29	35	38°			M431C756
	8	1415	1103	254	106	32	100		100	125	29	35	38°			M431C856
	9	1543	1199	286	106	32	100		100	125	29	35	38°			M431C956
60	6	2021	1718	245	267	43	260		260	286	29	35	51°			M431C666
	7	2193	1847	288	267	43	260		260	286	29	35	51°			M431C766

Type KHF II Threephase Tap Changer

Common Output per Phase / 20 - 60 kV / 150 - 400 A / 3 - 6 Positions / Setting 2.5 % per Position
(with HP Support)

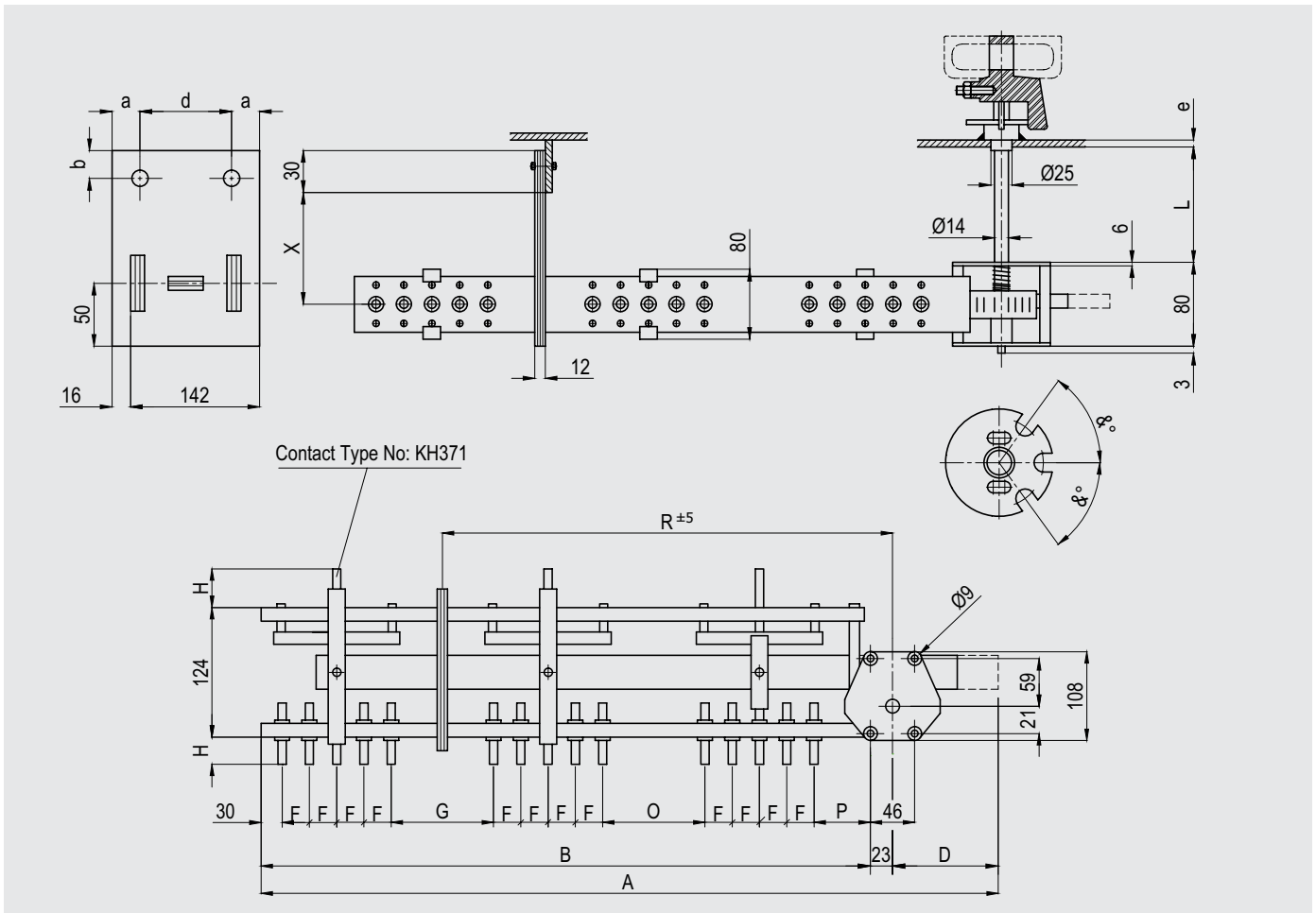

Voltage Class kV	Number of Positions	A	B	D	F	G	H	O	P	R	X min	&°	L	e	Unit No
20	3	574	457	94	32	70	Depends on fixed contacts	70	95	351	70	63°	Please specify when ordering		M433C346
	4	702	553	126	32	70		70	95	415	70	63°			M433C446
	5	830	649	158	32	70		70	95	479	70	63°			M433C546
	6	958	745	190	32	70		70	95	543	70	63°			M433C646
30	3	664	547	94	32	100		100	125	426	130	63°		M433C356	
	4	792	643	126	32	100		100	125	490	130	63°		M433C456	
	5	920	739	158	32	100		100	125	554	130	63°		M433C556	
	6	1048	835	190	32	100		100	125	618	130	63°		M433C656	
60	3	1233	1094	116	43	260		260	286	871	250	84°		M433C366	
	4	1405	1223	159	43	260		260	286	957	250	84°		M433C466	
	5	1577	1352	202	43	260		260	286	1043	250	81°		M433C566	

Type KHF II Threephase Tap Changer

Common Output per Phase / 20 - 60 kV / 150 - 400 A / 6 - 9 Positions / Setting 2.5 % per Position
(with HP Support)

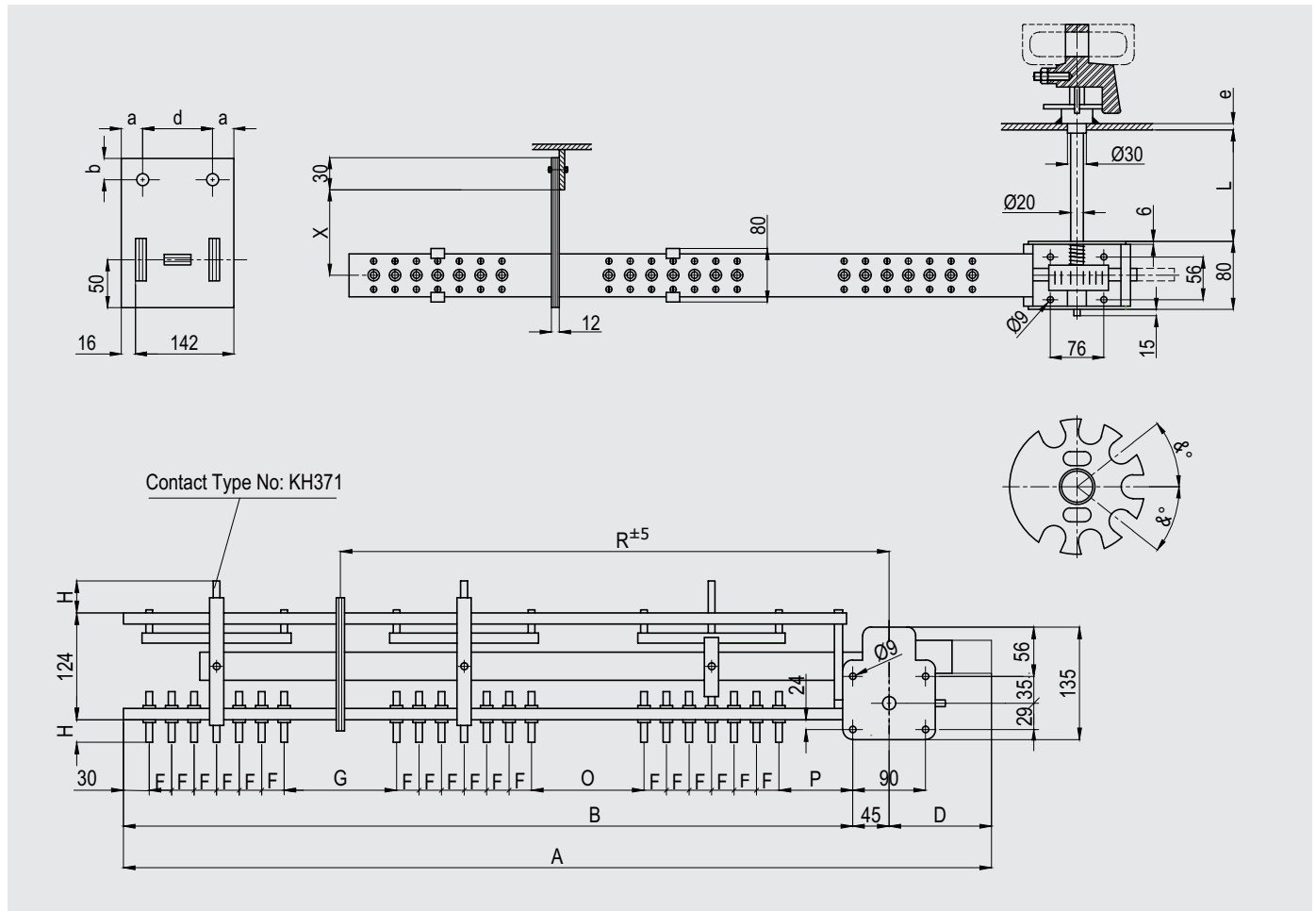

Voltage Class kV	Number of Positions	A	B	D	F	G	H	O	P	R	S	T	X min	& °	L	e	Unit No
20	7	1108	841	222	32	70	Depends on fixed contacts	70	95	629	29	35	70	38 °	Please specify when ordering		M433C746
	8	1236	937	254	32	70		70	95	693	29	35	70	38 °			M433C846
	9	1364	1033	286	32	70		70	95	757	29	35	70	38 °			M433C946
30	7	1198	931	222	32	100		100	125	704	29	35	130	38 °			M433C756
	8	1326	1027	254	32	100		100	125	768	29	35	130	38 °			M433C856
	9	1454	1123	286	32	100		100	125	832	29	35	130	38 °			M433C956
60	6	1771	1481	245	43	260		260	286	1151	29	35	250	51 °			M433C666
	7	1943	1610	288	43	260		260	286	1237	29	35	250	51 °			M433C766

Type KHF II Threephase Tap Changer

Star Diagram with outer-earthed Conductor / 20 - 60 kV / 150 - 400 A / 3 - 6 Positions /
Setting 2.5 % per Position (with Aluminium Support)

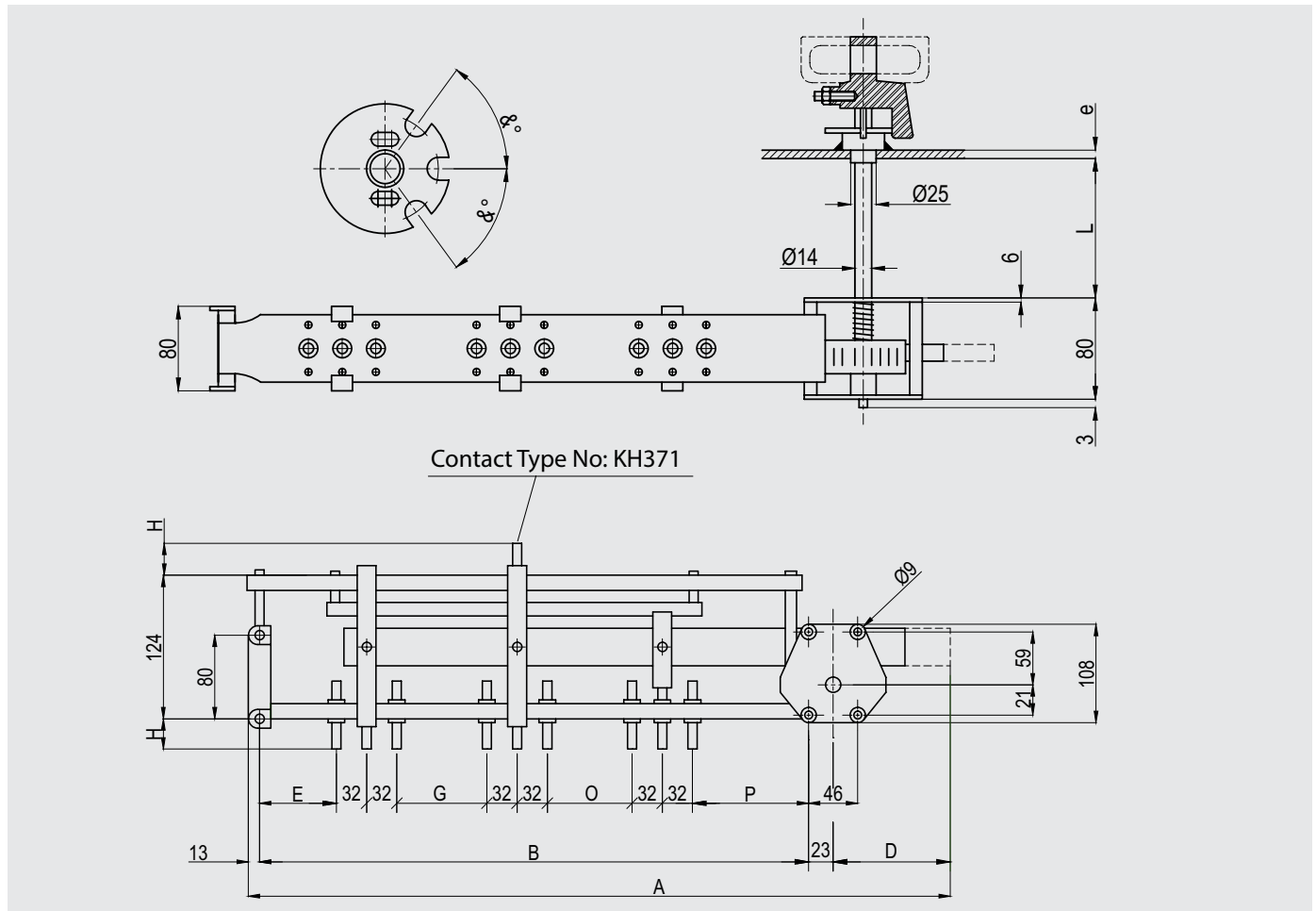

Voltage Class kV	Number of Positions	A	B	D	E	F	G	H	O	P	&°	L	e	Unit No
20	3	557	427	94	76	32	32	Depends on fixed contacts	32	95	63°	Please specify when ordering		M431F346
	4	685	523	126	76	32	32		32	95	63°			M431F446
	5	813	619	158	76	32	32		32	95	63°			M431F546
	6	941	715	190	76	32	32		32	95	63°			M431F646
30	3	617	487	94	106	32	32		32	125	63°		M431F356	
	4	745	583	126	106	32	32		32	125	63°		M431F456	
	5	873	679	158	106	32	32		32	125	63°		M431F556	
	6	1001	775	190	106	32	32		32	125	63°		M431F656	
60	3	1103	951	116	267	43	70		70	286	84°		M431F366	
	4	1275	1080	159	267	43	70		70	286	84°		M431F466	
	5	1447	1209	202	267	43	70		70	286	81°		M431F566	

Type KHF II Threephase Tap Changer

Opposite Contacts / Setting 2.5 % per Position (with Aluminium Support)

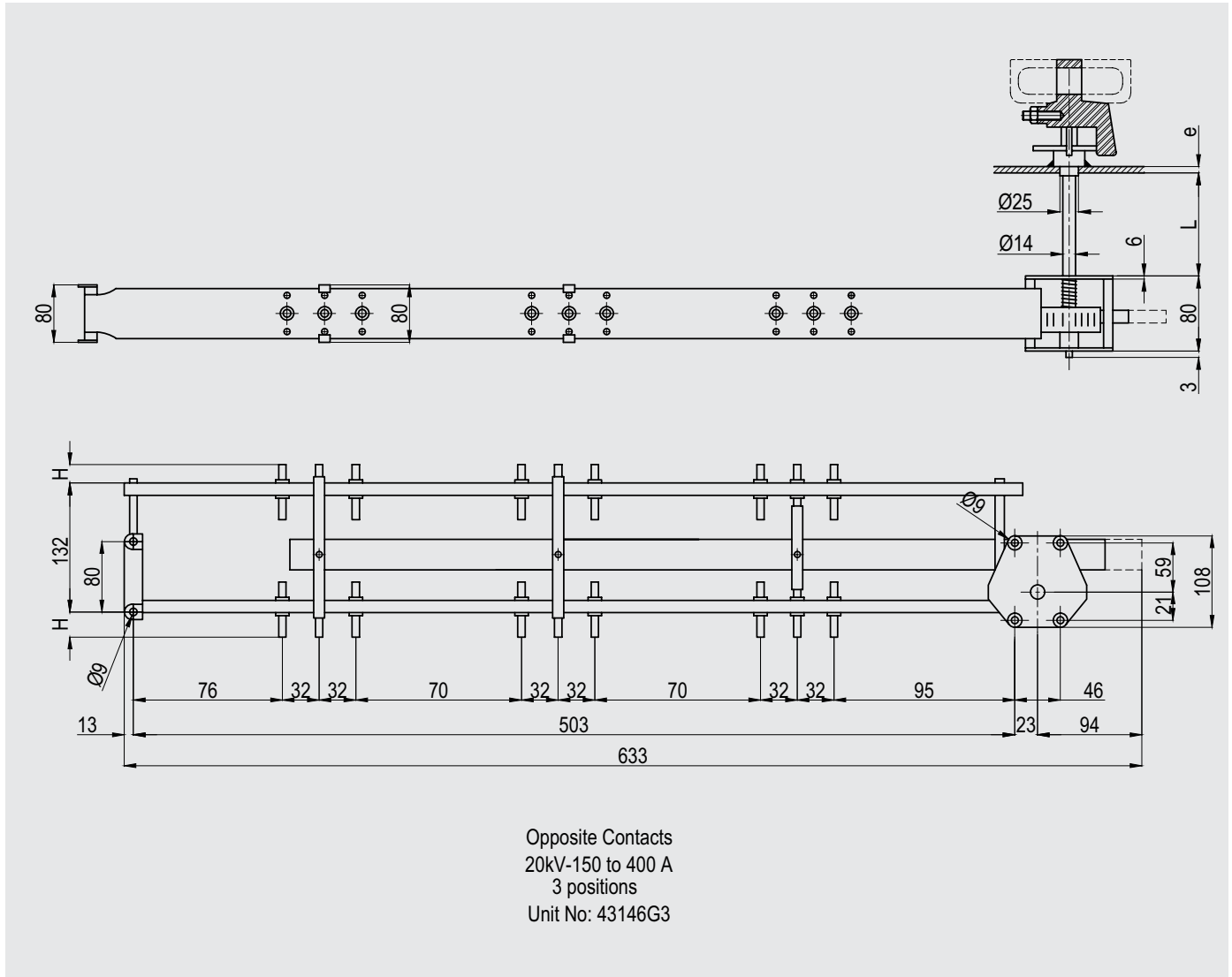

Type KHF II Threephase Tap Changer

Two-Stage / Delta diagram / 20 - 60 kV / 150 - 400 A / 2 - 6 Positions /
Setting 2.5 % per Position (with Aluminium Support)

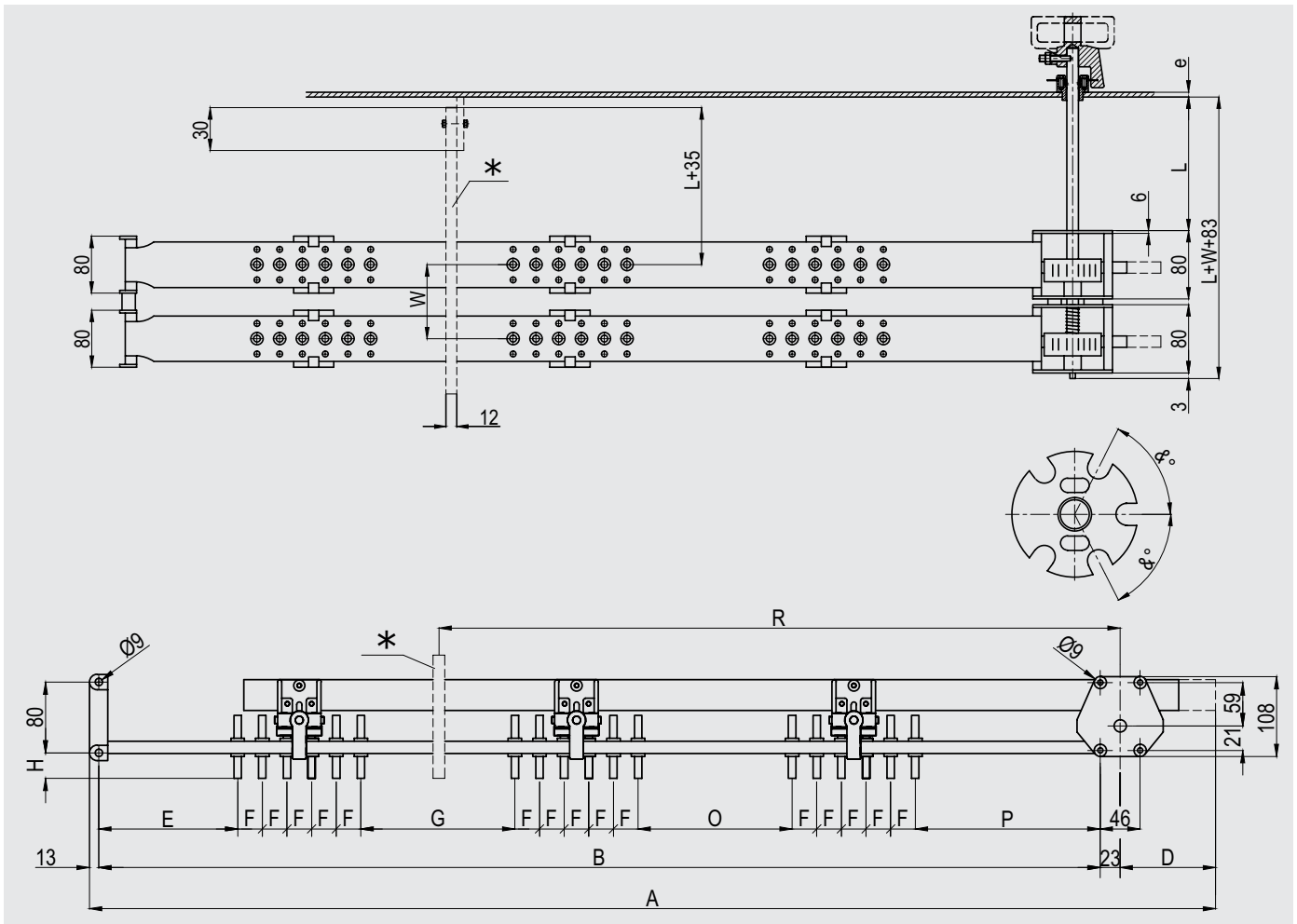

Voltage Class kV	Number of Positions	A	B	D	E	F	G	H	O	P	R	&°	L	e	Unit No
20	2	601	503	62	76	32	70	Depends on fixed contacts	70	95	351	63°	Please specify when ordering		M441D246
	3	729	599	94	76	32	70		70	95	415	63°		M441D346	
	4	857	695	126	76	32	70		70	95	479	63°		M441D446	
	5	985	791	158	76	32	70		70	95	543	63°		M441D546	
	6	1113	887	190	76	32	70		70	95	607	63°		M441D646	
30	2	721	623	62	106	32	100		100	125	426	63°		M431F356	
	3	849	719	94	106	32	100		100	125	490	63°		M431F456	
	4	977	815	126	106	32	100		100	125	554	63°		M431F556	
	5	1105	911	158	106	32	100		100	125	618	63°		M431F656	
	6	1233	1007	190	106	32	100		100	125	682	63°			
60	2	1140	1331	73	267	43	260	260	286	871	84°	M431F366			
	3	1612	1460	116	267	43	260	260	286	957	84°	M431F466			
	4*	1784	1589	159	267	43	260	260	286	1043	84°	M431F566			
	5*	1956	1718	202	267	43	260	260	286	1129	81°				

* additional supporting plate is used

Type KHF II Threephase Tap Changer

1. Stage Series Parallel Coupling 10 - 20 kV / 15 - 30 kV / 150 - 400 A

2. Stage Delta Diagram 20 - 30 kV / 150 - 400 A / 3 - 5 Positions / Setting 2.5 % per Position (Alu Support)

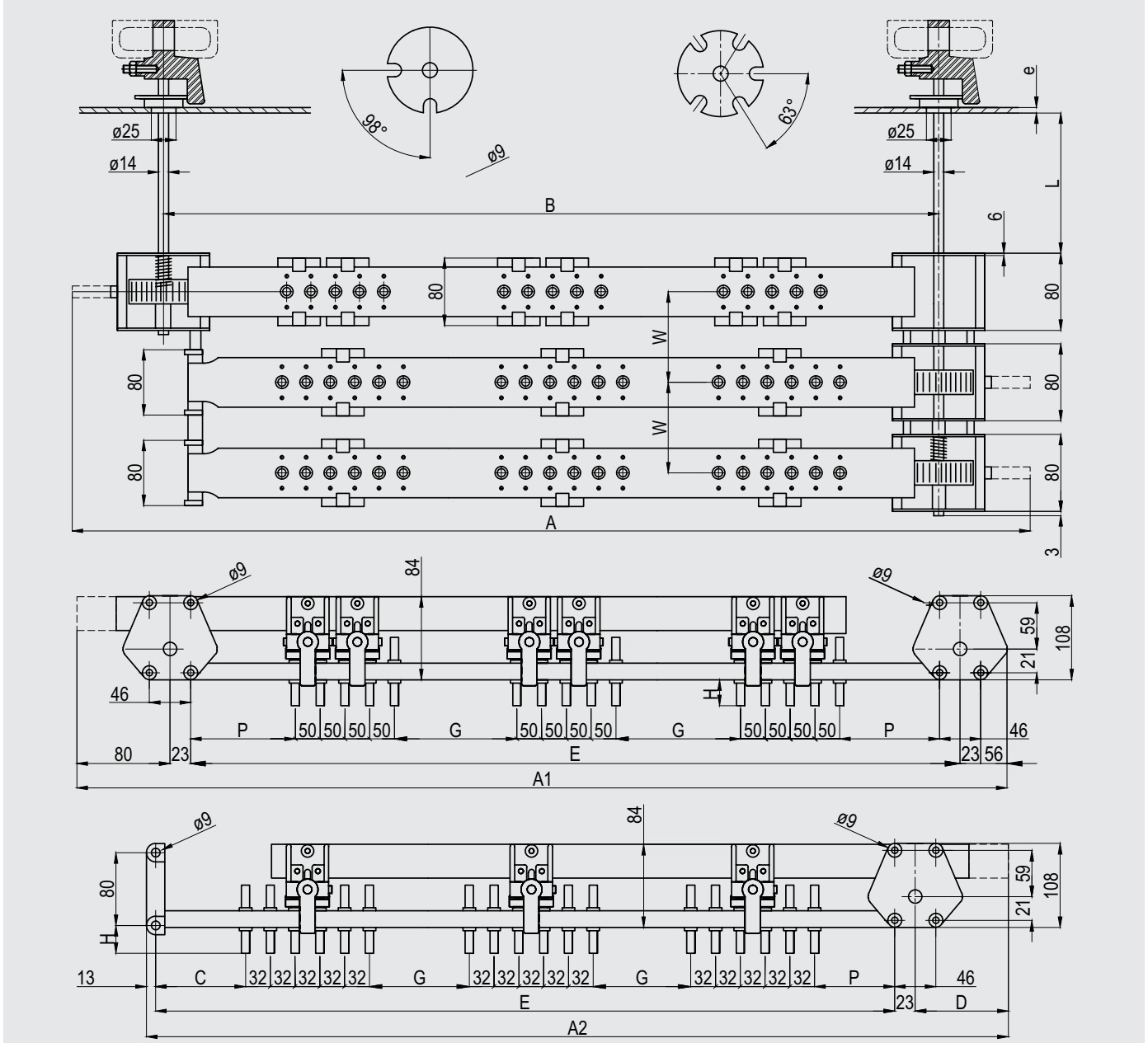

Voltage Class kV		Number of Positions	A	A1	A2	B	C	H	D	E	P	G	L	e	W	Unit No
Series Parallel	Delta															
10 - 20	20	3	1150	1112	1060	976	407	Depends on fixed contacts	94	930	95	70	Please specify when ordering			M451K376
		4	1182	1112	1092	976	311		126	930	95	70				M451K476
		5	1214	1112	1124	976	215		158	930	95	70				M451K576
15 - 30	30	3	1350	1312	1260	1176	457	94	1130	145	120	Please specify when ordering			M451K386	
		4	1382	1312	1292	1176	361	126	1130	145	120				M451K486	
		5	1414	1312	1324	1176	265	158	1130	145	120				M451K586	